

**MDG250DF4 | 6.8L | 250 kVA Prime**

MOBILE DIESEL GENERATOR SET

EPA Emissions Certification: Tier IV Final

**GENERAC®** | **MAGNUM**

**Standby Power Rating**

220 kW, 275 kVA, 60 Hz

**Prime Power Rating**

200 kW, 250 kVA, 60 Hz



Image used for illustration purposes only

**Codes and Standards**

Generac Magnum products are designed to the following standards:



CSA



NATM



TIER 4 FINAL EMISSIONS



ISO 8528-5

**Power When and Where You Need It**

Generac Magnum mobile diesel generators are designed and engineered to power a variety of projects, in the most extreme environments. Gensets are configured to meet customer needs, including choice of containment, cold weather packages, trailer options, and more.

Generac Magnum mobile diesel generators are manufactured to deliver reliable power, when and where you need it.

**STANDARD FEATURES**

**ENGINE SYSTEM**

- John Deere® 6068HFG06 – turbocharged + after-cooled, diesel engine
- Six cylinder
- 415 in<sup>3</sup> (6.8 L) displacement
- Tier IV Final (SCR + DOC)
- Rubber vibration dampers isolate engine/generator from frame
- Disposable air filter – paper element
- Variable Geometry Turbocharger (VGT)
- Electronic isochronous governing
- Variable speed fan drive

**FUEL SYSTEM**

- Steel, single wall fuel tank
- 358 gal (1355 L) diesel tank capacity
  - 24 hr run time – full load
- Fuel tank built into skid of generator set
- 34.4 gal (130.4 L) DEF tank capacity
- Fuel consumption at prime:
  - 100% – 13.9 gph (52.6 Lph)
  - 75% – 10.4 gph (39.4 Lph)
  - 50% – 7.2 gph (27.3 Lph)
- DEF consumption:
  - 100% standby – 0.45 gph (1.7 Lph)

**COOLING SYSTEM**

- Capable of operating at 108 °F (42 °C) ambient
- Low coolant shutdown
- Radiator and oil drains plumbed to exterior

**SYSTEM OUTPUTS**

- Link Board (lockable)
  - Three phase – 120 / 208V Low Wye
  - Three phase – 277 / 480V High Wye
- 220 kW / 275 kVA – standby, three phase
- 200 kW / 250 kVA – prime, three phase

**GENERATOR**

- 60 Hz engine/generator
- Marathon Electric
  - Brushless
  - 4-pole
  - Class H insulation
- Voltage regulation ± 1.0% with PM600 Voltage Regulator

**ENCLOSURE**

- Aluminum, sound attenuated enclosure
  - UV and fade resistant, high temperature cured, white polyester powder paint
  - Insulated and baffled
  - 78 dB(A) at 23 ft (7 m) – prime power (100% load)

- Fully lockable enclosure including doors and fuel fill
- Emergency stop switch located on outside of enclosure
- Central lifting point
- Multi-lingual operating/safety decals
- Document holder with operating manual including AC/DC wiring diagrams

**TRAILER**

- DOT approved tail, side, brake, and directional lights; recessed rear lights
- Transportation tie downs
- Safety chains with spring loaded safety hooks
- 3 in (76.2 mm) Lunette ring hitch
- Two 7,000 lb (3175 kg) axles with surge brakes
- 10,000 lb (4535 kg) tongue jack with footplate
- ST215/75R17.5 tubeless tires – 10 ply

**WARRANTY**

- 2 year limited warranty or 2000 hours
  - Unlimited hours covered in first year

**CERTIFICATIONS**

- CSA certified

**SYSTEM CONTROLS**

**Power Zone® Controller And Display**

- Backlit, 800 x 480 pixel resolution color display
- -40 °F to 185 °F (-40 °C to 85 °C) operating temperature range
- Automatic coarse voltage adjustment
- Integrated fine voltage adjustment
- PLC functionality

**Push Buttons For Easy Operation**

- Manual or Auto Start
- Engine Start
- Engine Stop/Reset
- Alarm Mute
- Operator Screens
  - Home
  - Engine
  - Generator
  - Voltage Adjust

**Scrolling Arrows for Diagnostic Information**

- Engine diagnostic display
  - Oil pressure
  - Engine temperature
  - Fuel level
  - Battery

- After-treatment inlet/outlet temperature
- Ash/soot levels
- Generator diagnostic display
  - System kW output display
  - Line output and frequency display
- Alarms
  - Warning
  - Shutdown
  - Electrical Trip
  - Engine
- Alarm list – warnings/shutdowns; 250 event history log – date/time stamp
  - Fuel level: warning – 15%; shutdown – 5%
  - Over speed protection: shutdown – 115%
  - Oil pressure: warning – 25 psi; shutdown – 20 psi
  - Coolant temperature: warning – 230 °F (110 °C); shutdown – 235 °F (113 °C)
  - Battery voltage: over – 15VDC; under – 11VDC
  - Generator over voltage: warning – 110%; electrical trip – 125%
  - Generator under voltage: warning – 91.4%; shutdown – 70%
  - Generator over frequency: warning – 102.5%; electrical trip – 110%
  - Generator under frequency: warning – 95%; electrical trip – 90%

- Inputs/Outputs
- Auto Schedule
- Status
- Configuration of controller, firmware, and connections

**ELECTRICAL CONTROLS**

- Remote start/stop contacts located in receptacle box
- Lockable control box door with diagnostics window
- Lockable lug box with safety switch
  - Trips main breaker when door is opened
  - Disables voltage regulator
- Output ground connection lug inside lug box
- 900A main breaker with shunt trip
- Convenience receptacles with individual breakers (restricted use in high wye mode)
  - Two 120V 20 amp GFCI duplex outlets – (NEMA 5-20R type)
  - Three 125/250V 50 amp, 3-pole, 4-wire Twist-lock (Non-NEMA 6369)
- Voltage adjustment integrated into Power Zone controller, ± 10%
- One 12V / 1000 CCA wet cell battery

**OPTIONS**

**ENGINE SYSTEM**

- Block heater
- Fuel filter heater
- CCV heater
- 60/40 coolant
- Positive air shutdown
- Cam locks
- 10A battery charger

**FUEL SYSTEM**

- 110% fluid containment

**TRAILER**

- Full size spare tire
- Tool box / storage bin
- 2-5/16" (5.9 cm) ball hitch
- Electric brakes
- Stabilizer jacks

**CABINET**

- Auxiliary fuel connection for day tank
- 36 hour tank
- Fire extinguisher

**CONTROL SYSTEM**

- 4-position selector switch
- PMG/DVR
- Paralleling
- Buck transformer
- Battery disconnect switch

**GENERATOR SYSTEM**

- SuperStart

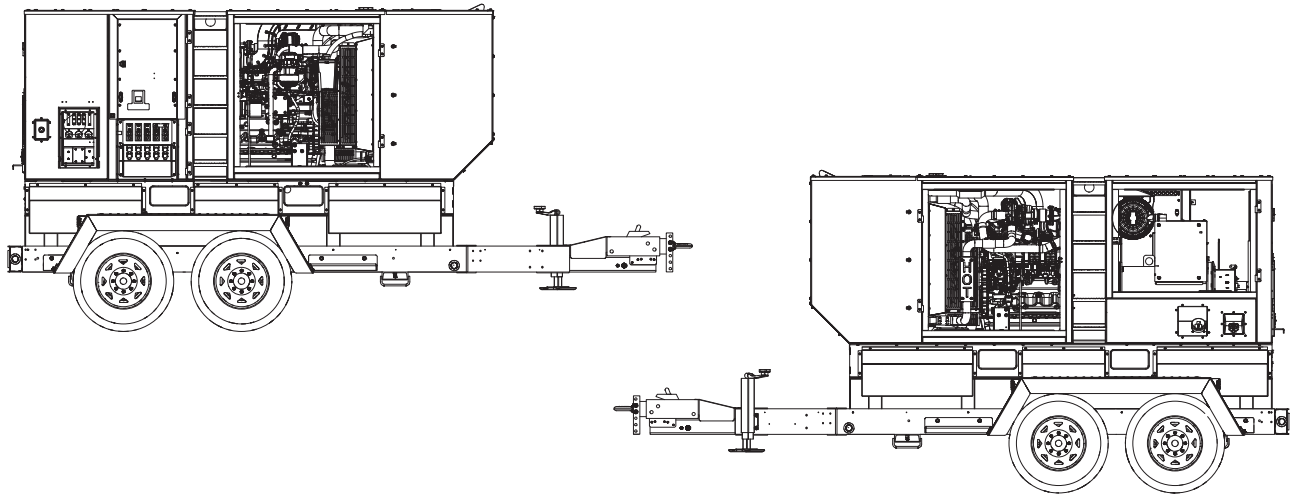

02491

**RATING DEFINITIONS**

Standby – Applicable for varying emergency load for the duration of a utility power outage.

Prime – Applicable for supplying power to a varying load in lieu of utility for an unlimited amount of running time.

\*Consult factory for availability

**APPLICATION AND ENGINEERING DATA**

**ENGINE SPECIFICATIONS**

General

Make	John Deere 6068HFG06
EPA Emissions Compliance	Tier IV Final
After-treatment System	SCR / DOC
Cylinder #	6
Type	In-line
Displacement	415 in <sup>3</sup> (6.8 L)
Bore – in (mm)	4.17 (106)
Stroke – in (mm)	5.0 (127.0)
Compression Ratio	17.2:1
Intake Air Method	Turbo / Air to Air

Engine Governing

Governor	Electronic
Frequency Regulation (Steady State)	2%

Lubrication System

Oil Pump Type	Gear
Oil Filter Type	Spin-on cartridge
Crankcase Capacity – qts (L)	34.3 (32.5)

Cooling System

Cooling System Type	Pressurized closed
Water Pump Type	Belt driven
Fan Type	Pusher
Fan Speed (rpm)	2,190
Fan Diameter – in (mm)	28 (710)
Coolant System Capacity – gal (L)	11 (42)

Fuel System

Fuel Type	Ultra low sulfur diesel
Fuel Specifications	EN 590 / ASTM D975
Fuel Filtering (microns)	2
Fuel Inject Pump Make	Denso HP6
Fuel Pump Type	Engine driven – belt
Injector Type	Electronic
Engine Type	Direct inject
Fuel Supply Line – in (mm)	0.375 (9.5)
Fuel Return Line – in (mm)	0.375 (9.5)

Engine Electrical System

System Voltage	12VDC
Battery Charger Alternator	STD
Battery Size	1,000 CCA
Battery Voltage	12VDC (1)
Ground Polarity	Negative

**ALTERNATOR SPECIFICATIONS**

Standard Model	431CSL6206
Superstart Model	433CSL6216
Poles	4
Field Type	Rotating
Insulation Class – Rotor	H
Insulation Class – Stator	H
Total Harmonic Distortion	< 5%

Telephone Interference Factor (TIF)	< 50
Standard Excitation	Brushless
Bearings	Double shielded, pre-lubricated
Coupling	Direct, flexible disc
Prototype Short Circuit Test	Yes
Voltage Regulator Type	AVR
Number of Sensed Phases	1
Regulation Accuracy (Steady State)	± 1%

**OPERATING DATA**

**POWER RATINGS**

	Standby		Prime	
Single-phase 120/240VAC @ 1.0pf (kW/kVA)	194 kW / 194 kVA	Amps: 807*	183 kW / 183 kVA	Amps: 763*
Three-phase 120/208VAC @ 0.8pf (kW/kVA)	220 kW / 275 kVA	Amps: 764*	200 kW / 250 kVA	Amps: 694
Three-phase 120/240VAC @ 0.8pf (kW/kVA)	220 kW / 275 kVA	Amps: 662	200 kW / 250 kVA	Amps: 601
Three-phase 277/480VAC @ 0.8pf (kW/kVA)	220 kW / 275 kVA	Amps: 331	200 kW / 250 kVA	Amps: 301

\* Circuit breaker limited

**STARTING CAPABILITIES (sKVA)**

sKVA vs. Voltage Dip

	208 VAC	480 VAC
Standard	TBA	TBA
SuperStart	32%	25%

**FUEL CONSUMPTION RATES\***

Diesel – gal/hr (l/hr)

Percent Load	Standby	Prime
25%	4.7 (17.8)	4.4 (16.7)
50%	7.8 (29.5)	7.2 (27.3)
75%	11.4 (43.2)	10.4 (39.4)
100%	15.4 (58.3)	13.9 (52.6)

Deration – Operational characteristics consider maximum ambient conditions. Derate factors may apply under atypical site conditions.

Please consult a Generac Mobile Products Authorized Service Dealer for additional details. All performance ratings in accordance with ISO3046, BS5514, ISO8528, ISO8665, ISO3046, SAE J1228, SAE J1995, and DIN6271 standards.

**MDG250DF4 | 6.8L | 250 kVA Prime**

**MOBILE DIESEL GENERATOR SET**

EPA Emissions Certification: Tier IV Final

**GENERAC®**

**MAGNUM**

**DIMENSIONS AND WEIGHTS\***

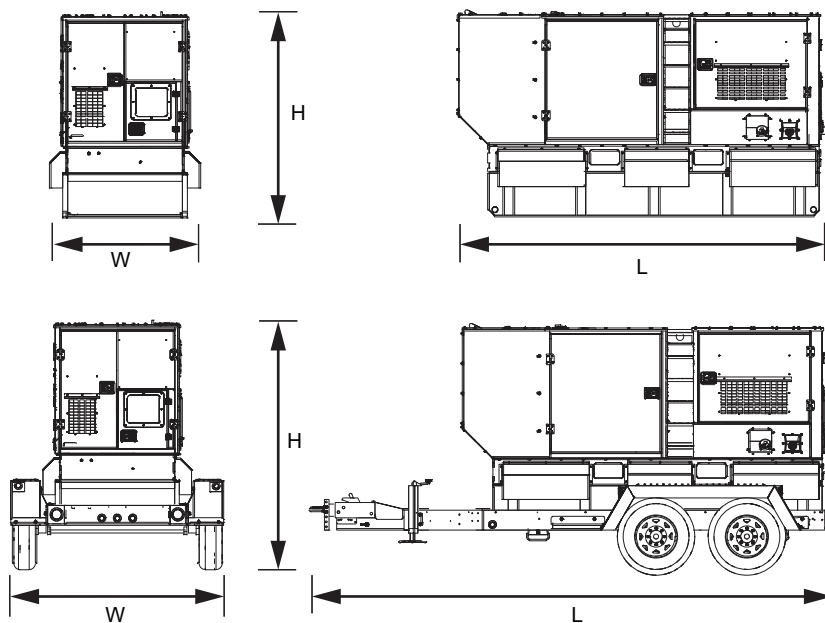

	Run Time Hours	Usable Capacity Gal (L)	L x W x H in (m)	Weight lbs (kg)
Skid	24	343 (1,297)	145 (3.7) x 60 (1.5) x 85 (2.1)	Dry: 6,898 (3,129) Operating: 9,411 (4,269)
Trailer	24	343 (1,297)	208 (5.3) x 86 (2.2) x 104 (2.6)	Dry: 8,863 (4,020) Operating: 11,376 (5,160)

\* All measurements are approximate and for estimation purposes only.

**YOUR FACTORY RECOGNIZED GENERAC MOBILE PRODUCTS DEALER**

Specification characteristics may change without notice. Dimensions and weights are for preliminary purposes only. Please consult a Generac Mobile Products Authorized Service Dealer for detailed installation drawings.