

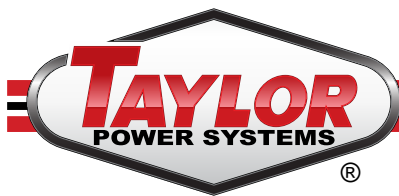

EPA Certified / Stationary Emergency

OUTPUT POWER OPTIONS					Natural Gas				LP Vapor				sKVA
					125°C		105°C		125°C		105°C		
Make	Voltage	Alternator	Phase	Hertz	STANDBY	CONTINUOUS	STANDBY	CONTINUOUS	STANDBY	CONTINUOUS	STANDBY	CONTINUOUS	30% Voltage Dip
Marathon	600	361PSL1633	3	60	60/75	72	51/63	61	60/75	72	52/65	63	189
	277/480	361CSL1602	3	60	60/75	90	51/63	77	60/75	90	52/65	78	293
	120/208	361CSL1602	3	60	60/75	208	51/63	177	60/75	208	52/65	181	220
	120/240	361CSL1602	3	60	60/75	181	51/63	154	60/75	181	52/65	157	220
	120/240	361CSL1602	1	60	55/55	229	51/51	213	55/55	229	52/65	217	91
Marathon	120/240	361CSL1613	1	60	60/60	250	51/51	213	60/60	250	52/65	217	128
	277/480	362CSL1604	3	60	60/75	90	54/67	81	62/78	93	55/68	83	318
	120/208	362CSL1604	3	60	60/75	208	54/67	188	62/78	215	55/68	191	238
	120/240	362CSL1604	3	60	60/75	181	54/67	163	62/78	187	55/68	166	238
Stamford	120/240	362CSL1604	1	60	60/75	250	54/54	225	62/62	258	55/55	229	128
	600	UCI224F17	3	60	60/75	72	51/63	61	60/75	72	52/65	63	293
	277/480	UCI224F311	3	60	60/75	90	51/63	77	60/75	90	52/65	78	257
	120/208	UCI224F311	3	60	60/75	208	51/63	177	60/75	208	52/65	181	194
	120/240	UCI224F311	3	60	60/75	181	51/63	154	60/75	181	52/65	157	194
120/240	UCI224F311	1	60	56/56	233	50/50	208	56/56	233	50/50	208	137	
120/240	UCI224F06	1	60	60/60	250	51/51	213	60/60	250	52/52	217	168	



Engine Data

Manufacturer	GM
Model	5.7L
Aspiration	Natural Aspiration
Arrangement	V-8, 4-Cycle
Firing Order	1-8-4-3-6-5-7-2
Displacement: L (in. ³)	5.7 (350)
Bore: mm (in.)	101.6 (4.00)
Stroke: mm (in.)	88.4 (3.48)
Compression Ratio	9.1:1
Gross Horsepower: Natural Gas	104.7
LP Vapor	113.2
Rated RPM	1800
Governor	Isochronous
Speed Regulation	±0.5%

Engine Liquid Capacity

Oil system: qt. (L)	5.0 (4.7)
Engine Cooling System Capacity: gal (L)	2.1 (7.8)

Engine Electrical

Electric Volts: DC	12
Cold Cracking Amps	650
Battery(s) Required	1

Fuel System

Fuel Type	Natural Gas, LP Vapor or Dual Fuel
Fuel Supply Inlet:	
Natural Gas	1.25" NPT
LP Vapor	1.25" NPT
Fuel Supply Pressure: in. H ₂ O (kPa)	7-11 (1.74-2.74)

Filters and Quantity

Air Cleaner Quantity	1
Oil Filter(s) Quantity	1

Air Requirements

Air Filter(s) Type	Dry
Air Flow: CFM (m ³ /min)	6,000 (170)
Max Air Intake Restriction: in. H ₂ O (kPa)	
Clean	3.00 (1.49)
Dirty	13.00 (3.24)
Combustion Air: CFM (m ³ /min)	173.0 (4.9)

Exhaust System

Gas Temperature: °F (°C)	1200 (649)
Gas Flow: CFM (m ³ /min)	552.7 (15.82)
Max Exhaust Back Pressure: in. H ₂ O (kPa)	40.9 (10.2)
Exhaust Outlet Size: in. (mm)	3.0 (76)

Cooling System

Heat Rejection to Ambient: kW (BTUM)	30.9 (1760)
Heat Rejection to Coolant: kW (BTUM)	54.8 (3120)
Coolant Flow: gpm (Lpm)	31 (117.3)

Fuel Consumption Natural Gas - 130°C

At 100% of Power Rating: CFH (m ³ /hr)	790 (22.4)
At 75% of Power Rating: CFH (m ³ /hr)	685 (19.4)
At 50% of Power Rating: CFH (m ³ /hr)	520 (14.7)
At 25% of Power Rating: CFH (m ³ /hr)	350 (9.9)

Fuel Consumption Natural Gas - 105°C

At 100% of Power Rating: CFH (m ³ /hr)	758 (21.5)
At 75% of Power Rating: CFH (m ³ /hr)	638 (18.1)
At 50% of Power Rating: CFH (m ³ /hr)	483 (13.7)
At 25% of Power Rating: CFH (m ³ /hr)	334 (9.5)

Fuel Consumption LP Vapor - 130°C

At 100% of Power Rating: CFH (m ³ /hr)	330 (9.3)
At 75% of Power Rating: CFH (m ³ /hr)	250 (7.1)
At 50% of Power Rating: CFH (m ³ /hr)	190 (5.4)
At 25% of Power Rating: CFH (m ³ /hr)	135 (3.8)

Fuel Consumption LP Vapor - 105°C

At 100% of Power Rating: CFH (m ³ /hr)	294 (8.3)
At 75% of Power Rating: CFH (m ³ /hr)	231 (6.6)
At 50% of Power Rating: CFH (m ³ /hr)	179 (5.1)
At 25% of Power Rating: CFH (m ³ /hr)	128 (3.6)

GENERAL GUIDELINES FOR DERATION: Altitude: Derate 0.5% per 100m (328 ft.) Elevation above 1000m (3279 ft.) Temperature: Derate 1.0% per 10°C (18°F) temperature above 25°C (77°F)

RATINGS: All three-phase units are rated at 0.8 power factor. All single-phase units are rated at 1.0 power factor.

125° RATINGS: 125° apply to installations served by a reliable utility source. The standby rating is applicable to varying loads for the duration of a power outage. There is no overload capability for this rating. Ratings are in accordance with ISO-3046/1, BS 5514, AS 2789, and DIN 6271.

105° RATINGS: 105° ratings apply to installations where utility power is unavailable or unreliable. At varying load the number of generator set operating hours is unlimited. A 10% overload capacity is available for one hour in twelve. Ratings are in accordance with ISO-8528/1, overload power in accordance with ISO-3046/1, BS5514, AS2789, and DIN 6271. For limited running time and base load ratings consult the factory. The generator set manufacturer reserves the right to change the design or specifications without notice and without any obligation or liability whatsoever.

Alternator Data

Manufacturer	Marathon
Type	PMG
Insulation NEMA Rise/Temp	NEMA H/125°C
Hertz	60
Phase	3
RPM	1800
Leads	12
Amortisseur Windings	Full
CFM Cooling Required	700
Voltage Regulator	PM500
Sensing	Three Phase
Voltage Regulation, No Load - Full Load	0.5%

Optional 0.25% Regulation DVR2000E+ Available

Features

- NEMA MG1-32, BS5000, and IEC 34-1 compliant; CE & CSA Certified and UL Listed
- Self-ventilated and drip proof construction
- Two-thirds pitch stator and skewed rotor
- Wet wound, epoxied field windings
- Designed to withstand overspeeds of up to 125%
- Hybrid analog/digital voltage regulator
- Under frequency protection
- Under frequency indication light
- Less than one cycle response time
- Over excitation protection
- Over excitation indication light
- Easy access front-panel adjustments
- Over voltage protection shutdown
- Analog input for paralleling

Alternator Data

Manufacturer	Stamford
Type	PMG
Insulation NEMA Rise/Temp	NEMA H/125°C
Hertz	60
Phase	3
RPM	1800
Leads	12
Amortisseur Windings	Full
CFM Cooling Required	595
Voltage Regulator	MX341
Sensing	Single Phase
Voltage Regulation, No Load - Full Load	1.0%

Features

- BS EN 60034, BS5000, VDE 0530, NEMA MG1-32, IEC34, CSA C22.2-100, and AS1359 complaint
- IP23 enclosure
- Dynamically balanced to exceed BS6861:Part 1 Grade 2.5 vibration standard
- Quality assurance to BS EN ISO 9001
- Self-ventilated and drip proof construction
- Two-thirds pitch stator and skewed rotor
- Heavy duty bearings
- Fully guarded
- Overexcitation protection
- Under frequency protection
- Analog input
- Overvoltage protection
- Paralleling compatible
- Single-phase sensing



DGC2020 Digital Controller

- Integrated engine-genset control, protection, and metering
- Microprocessor allows for exact measurement, setpoint adjustment, and timing functions
- Front panel 3 position controls and indicators enable quick and simple operation
- Emergency stop push button and an Alarm Horn with silence button
- A wide temperature-range liquid crystal display (LCD) with backlighting
- SAE J1939 Engine ECU communications
- Remote RS-485 communications for Optional RDP-110 Remote Annunciator
- 4 programmable contact inputs and 10 contact outputs (2 ADC rated)
- Modbus Communications with RS-485, Battery Backup for Real Time Clock, UL recognized, CSA certified, CE approved, HALT (Highly Accelerated Life Tests) tested
- IP 54 Front Panel rating with integrated gasket and NFPA 110 Level 1 Compatible.
- Manual Override Keyswitch



Analog Controller with Emergency Bypass Key Switch

- Automatic CANBUS Engine Control
- Oil Pressure, Water Temperature, Battery Voltage and RPM Gauges
- Automatic Gauge Zeroing on Shutdown
- AC Voltage, Frequency, Percent of Load, and Run-Time Metering
- 3-Position Auto-Off-Manual Control Switch
- LED Status Lights: Low Oil Pressure, High Temperature, Overcrank, Overspeed, & Engine Start

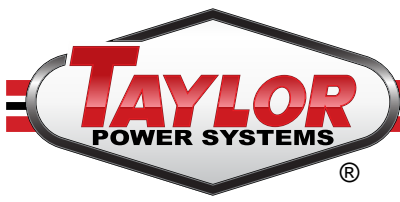

Standard Features:

Warranty

2 Year Standard
5 Year Comprehensive

- Heavy Duty Steel Base
- Vibration Isolators
- Oil Drain Valve with Extension
- Battery Rack & Cables
- High Ambient Unit Mounted Radiator
- Battery Charging Alternator
- Factory Powder Coating
- Factory Test
- Owner's Manual

Controller Options

DGC-2020HD Controller
Fiber Optic Ethernet (DGC-2020HD)
RS-232 Port & Generator Protection (DGC-2020)
Flush or Surface Mount Remote Annunciator
Remote Mount Break Glass E-Stop Switch

Miscellaneous Options:

- Battery Charger
- Coolant Drain Kit
- Block Heater
- Line Circuit Breaker
- Pad Type Battery Heater
- Battery Heater Blanket w/Thermostat
- Oil Pan Heater
- Generator Strip Heater

Narrow Skid Base Open Unit

Options:

- Radiator Duct Flange
- Flex Exhaust
- Critical Silencer
- Wide Skid Base

OVERALL SIZE: 78"L x 36"W x 45"H
 Approximate Weight: 1,500 lbs.

Note: Dimensions and weights reflect standard open unit with no options and are subject to change.

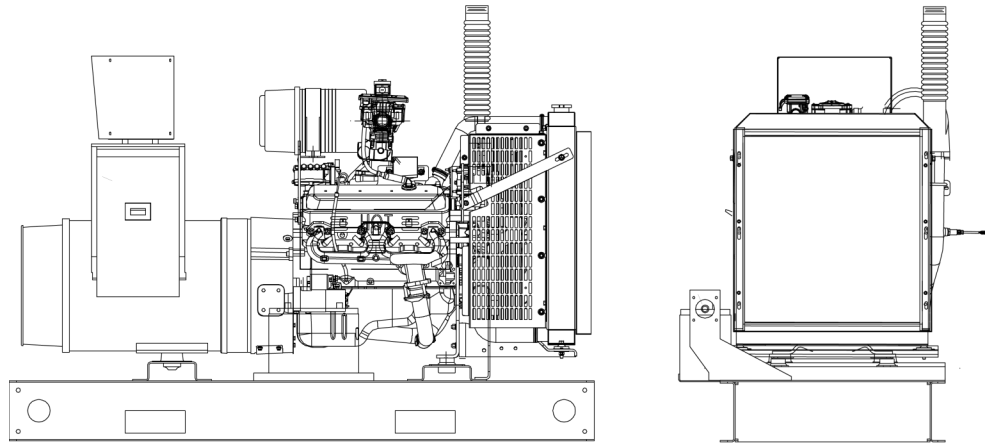

Standard Enclosed Unit

Options:

- Sound Attenuated Enclosure
- Load Center, Lights & GFI Receptacle

OVERALL SIZE: 102"L x 52"W x 64"H
 Approximate Weight: 2,500 lbs.

Note: Dimensions and weights reflect standard enclosed unit with no options and are subject to change.

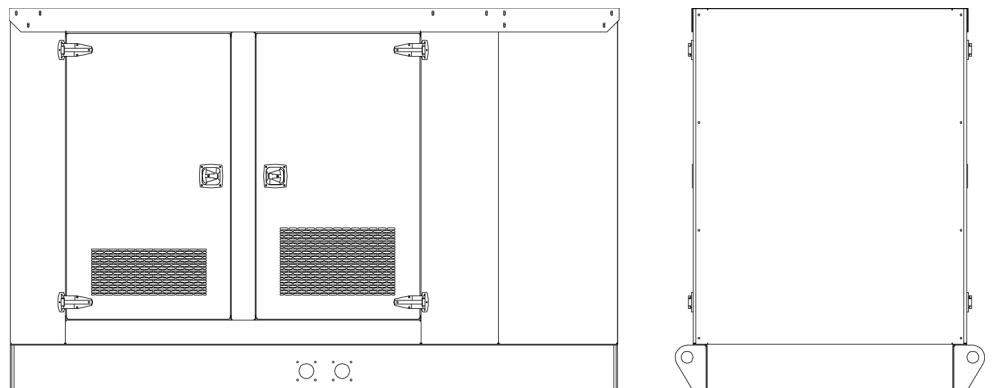

Note: The above drawings are provided for reference only and should not be used for planning installation. Contact your local distributor for more information.