

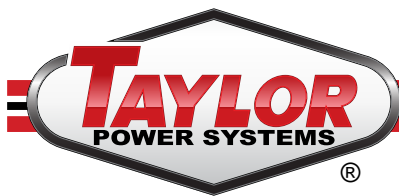

### EPA Certified / Stationary Emergency

OUTPUT POWER OPTIONS					125°C RISE STANDBY RATING		105°C RISE CONTINUOUS RATING		sKVA
Make	Voltage	Alternator	Phase	Hertz	kW/kVA	Amps	kW/kVA	Amps	30% Voltage Dip
Marathon	600	741RSS4282	3	60	1000/1250	1204	920/1150	1108	1550
	277/480	741RSL4045	3	60	1000/1250	1505	920/1150	1385	2600
	120/208	741RSL4045	3	60	1000/1250	3474	920/1150	3196	2600
	120/240	741RSL4045	3	60	1000/1250	3011	920/1150	2770	2600
Marathon	277/480	742RSL4049	3	60	1020/1275	1535	925/1156	1392	3110
	120/208	742RSL4049	3	60	1020/1275	3543	925/1156	3213	2260
	120/240	742RSL4049	3	60	1020/1275	3071	925/1156	2785	2260
Stamford	600	HCI634J07	3	60	1000/1250	1204	920/1150	1108	3000
	277/480	HCI634J311	3	60	1000/1250	1505	920/1150	1385	3080
	120/208	HCI634J311	3	60	920/1150	3196	850/1063	2953	2330
	120/240	HCI634J311	3	60	920/1151	2770	131/164	2559	2330



**Engine Data**

Manufacturer	Mitsubishi
Model	S12H-Y2PTAW-1
Aspiration	Turbocharged
EPA Tier	2
Charge Air Cooling System	Inter-Cooler
Arrangement	60°V, 4-Cycle
Displacement: L (in. <sup>3</sup> )	37.11 (2265)
Bore: mm (in.)	150 (5.91)
Stroke: mm (in.)	175 (6.89)
Compression Ratio	14.5:1
BMEP: psi (kPa)	297.0 (2047.7)
Brake Horsepower	1474
Rated RPM	1800
Governor	Electronic
Speed Regulation	±0.25%

**Engine Liquid Capacity**

Oil System: qt. (L)	211.3 (200.0)
Capacity of Water Jacket: gal (L)	21.9 (83)
Capacity of Air Cooler: gal (L)	4.5 (17)

**Engine Electrical**

Electric Volts: DC	24
Cold Cranking Amps	1100
Battery(s) Required	4

**Fuel System**

Fuel Injector	Mitsubishi
Maximum Suction Head of Feed Pump: in. Hg (mm Hg)	3.0 (75.0)
Maximum Static Head of Return: in. Hg (mm Hg)	8.7 (220.0)
Recommended Fuel	#2 Low Sulfur Diesel

**Air Requirements**

Air Filter(s) Type	Dry
Combustion Air Flow: CFM (m <sup>3</sup> /min)	3,602 (102)
Cooling Fan Air Flow: CFM (m <sup>3</sup> /min)	42,166 (1194)
Maximum Air Intake Restriction	
Clean: in. H <sub>2</sub> O (kPa)	15.70 (3.91)
Dirty: in. H <sub>2</sub> O (kPa)	25.00 (6.23)

**Exhaust System**

Heat Rejection to Exhaust: kW (BTUM)	1004 (57,133)
Gas Flow: CFM (m <sup>3</sup> /min)	9,534 (270)
Maximum Exhaust Back Pressure: in. H <sub>2</sub> O (kPa)	23.60 (5.88)

**Sound Level**

Open Unit Without Exhaust: dBA 3.2 ft (1M)	113
--	-----

**Filters and Quantity**

Air Cleaner Quantity	1
Oil Filter(s) Quantity	1
Fuel Filter(s) Quantity	2

**Fuel Consumption - 125°C**

At 100% of Power Rating: gal/hr (L/hr)	75.0 (284.0)
At 75% of Power Rating: gal/hr (L/hr)	59.7 (226.0)
At 50% of Power Rating: gal/hr (L/hr)	39.9 (151.0)
At 25% of Power Rating: gal/hr (L/hr)	21.4 (81.0)

**Fuel Consumption - 105°C**

At 100% of Power Rating: gal/hr (L/hr)	70.3 (266.0)
At 75% of Power Rating: gal/hr (L/hr)	54.7 (207.0)
At 50% of Power Rating: gal/hr (L/hr)	35.9 (136.0)
At 25% of Power Rating: gal/hr (L/hr)	20.1 (76.0)

**Cooling System**

Heat Rejection to Air Cooler: kW (BTUM)	328 (18,633)
Heat Rejection to Coolant: kW (BTUM)	417 (23,715)
Heat Rejection to Ambient: kW (BTUM)	89 (5,082)
Coolant Flow: gal/min (L/min)	383 (1450)
Coolant Flow to Intercooler: gal/min (L/min)	132 (500)

**GENERAL GUIDELINES FOR DERATION:** Altitude: Derate 0.5% per 100m (328 ft.) Elevation above 1000m (3279 ft.) Temperature: Derate 1.0% per 10°C (18°F) temperature above 25°C (77°F)

**RATINGS:** All three-phase units are rated at 0.8 power factor. All single-phase units are rated at 1.0 power factor.

**125° RATINGS:** 125° apply to installations served by a reliable utility source. The standby rating is applicable to varying loads for the duration of a power outage. There is no overload capability for this rating. Ratings are in accordance with ISO-3046/1, BS 5514, AS 2789, and DIN 6271.

**105° RATINGS:** 105° ratings apply to installations where utility power is unavailable or unreliable. At varying load the number of generator set operating hours is unlimited. A 10% overload capacity is available for one hour in twelve. Ratings are in accordance with ISO-8528/1, overload power in accordance with ISO-3046/1, BS5514, AS2789, and DIN 6271. For limited running time and base load ratings consult the factory. The generator set manufacturer reserves the right to change the design or specifications without notice and without any obligation or liability whatsoever.

## Alternator Data

Manufacturer	Marathon
Type	PMG
Insulation NEMA Rise/Temp	NEMA H/125°C
Hertz	60
Phase	3
RPM	1800
Leads	12
Amortisseur Windings	Full
CFM Cooling Required	3505
Voltage Regulator	DVR2000E+
Sensing	Three Phase
Voltage Regulation, No Load - Full Load	0.25%

## Features

- NEMA MG1-32, BS5000, and IEC 34-1 compliant; CE & CSA Certified and UL Listed
- Self-ventilated and drip proof construction
- Two-thirds pitch stator and skewed rotor
- Wet wound, epoxied field windings
- Designed to withstand overspeeds of up to 125%
- Digital voltage regulator
- Under frequency protection
- Under frequency indication light
- Less than one cycle response time
- Over excitation protection
- Over excitation indication light
- Easy access front-panel adjustments
- Over voltage protection shutdown
- Analog input for paralleling

## Alternator Data

Manufacturer	Stamford
Type	PMG
Insulation NEMA Rise/Temp	NEMA H/125°C
Hertz	60
Phase	3
RPM	1800
Leads	12
Amortisseur Windings	Full
CFM Cooling Required	4156
Voltage Regulator	MX321
Sensing	Three Phase
Voltage Regulation, No Load - Full Load	0.5%

## Features

- BS EN 60034, BS5000, VDE 0530, NEMA MG1-32, IEC34, CSA C22.2-100, and AS1359 complaint
- IP23 enclosure
- Dynamically balanced to exceed BS6861:Part 1 Grade 2.5 vibration standard
- Quality assurance to BS EN ISO 9001
- Self-ventilated and drip proof construction
- Two-thirds pitch stator and skewed rotor
- Heavy duty bearings
- Fully guarded
- Overexcitation protection
- Under frequency protection
- Analog input
- Overvoltage protection
- Paralleling compatible
- Single-phase sensing



## DGC2020 Digital Controller

- Integrated engine-genset control, protection, and metering
- Microprocessor allows for exact measurement, setpoint adjustment, and timing functions
- Front panel 3 position controls and indicators enable quick and simple operation
- Emergency stop push button and an Alarm Horn with silence button
- A wide temperature-range liquid crystal display (LCD) with backlighting
- SAE J1939 Engine ECU communications
- Remote RS-485 communications for Optional RDP-110 Remote Annunciator
- 4 programmable contact inputs and 10 contact outputs (2 ADC rated)
- Modbus Communications with RS-485, Battery Backup for Real Time Clock, UL recognized, CSA certified, CE approved, HALT (Highly Accelerated Life Tests) tested
- IP 54 Front Panel rating with integrated gasket and NFPA 110 Level 1 Compatible.
- Manual Override Keyswitch



## Analog Controller with Emergency Bypass Key Switch

- Automatic CANBUS Engine Control
- Oil Pressure, Water Temperature, Battery Voltage and RPM Gauges
- Automatic Gauge Zeroing on Shutdown
- AC Voltage, Frequency, Percent of Load, and Run-Time Metering
- 3-Position Auto-Off-Manual Control Switch
- LED Status Lights: Low Oil Pressure, High Temperature, Overcrank, Overspeed, & Engine Start



## Standard Features:

### Warranty

2 Year Standard
5 Year Comprehensive

- Heavy Duty Steel Base
- Vibration Isolators
- Oil Drain Valve with Extension
- Battery Rack & Cables
- High Ambient Unit Mounted Radiator
- Battery Charging Alternator
- Factory Powder Coating
- Factory Test
- Owner's Manual

### Controller Options

DGC-2020HD Controller
Fiber Optic Ethernet (DGC-2020HD)
RS-232 Port & Generator Protection (DGC-2020)
Flush or Surface Mount Remote Annunciator
Remote Mount Break Glass E-Stop Switch

### Miscellaneous Options:

- Battery Charger
- Coolant Drain Kit
- Block Heater
- Line Circuit Breaker
- Pad Type Battery Heater
- Battery Heater Blanket w/Thermostat
- Oil Pan Heater
- Generator Strip Heater

## Narrow Skid Base Open Unit

### Options:

- Radiator Duct Flange
- Flex Exhaust
- Critical Silencer
- Wide Skid Base

OVERALL SIZE: 189"L x 82"W x 102"H  
 Approximate Weight: 22,110 lbs.

*Note: Dimensions and weights reflect standard open unit with no options and are subject to change.*

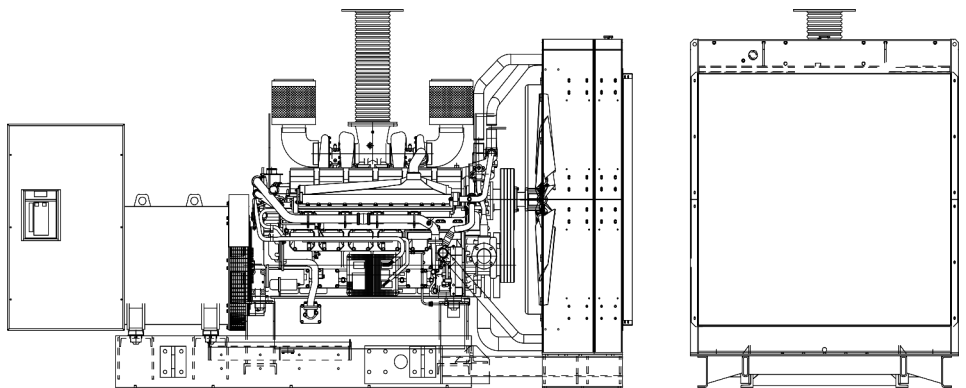

## Standard Enclosed Unit

### Options:

- Sound Attenuated Enclosure
- Load Center, Lights & GFI Receptacle
- Sub-Base Fuel Tank

OVERALL SIZE: 292"L x 100"W x 132"H

*Note: Dimensions reflect standard enclosed unit with no options and are subject to change.*

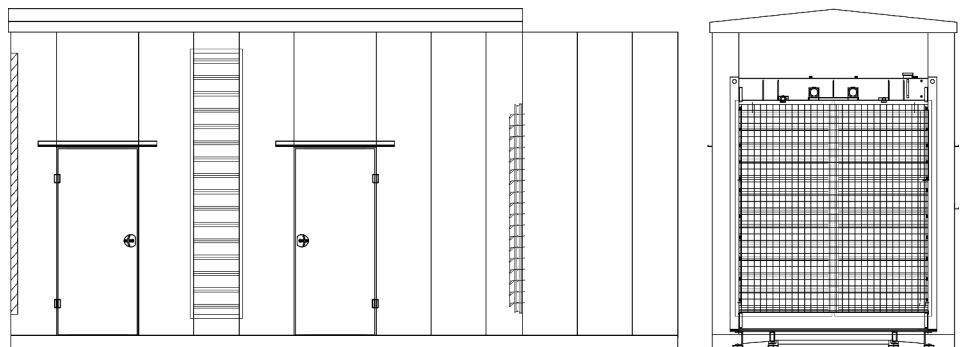

**Note: The above drawings are provided for reference only and should not be used for planning installation.**

**Contact your local distributor for more information.**