



EPA Certified / Stationary Emergency

OUTPUT POWER OPTIONS					125°C RISE STANDBY RATING		105°C RISE CONTINUOUS RATING		sKVA
Make	Voltage	Alternator	Phase	Hertz	kW/kVA	Amps	kW/kVA	Amps	30% Voltage Dip
Marathon	600	362PSL1635	3	60	80/100	96	73/91	88	317
	277/480	362CSL1604	3	60	80/100	120	73/91	110	317
	120/208	362CSL1604	3	60	80/100	278	72/90	250	238
	120/240	362CSL1604	3	60	80/100	241	72/90	217	238
	120/240	362CSL1604	1	60	66/66	275	61/61	254	128
	120/240	363CSL1617	1	60	80/80	333	72/72	300	310
Marathon	277/480	362CSL1606	3	60	84/105	126	75/94	113	378
	120/208	362CSL1606	3	60	84/105	292	75/94	261	284
	120/240	362CSL1606	3	60	84/105	253	75/94	226	284
	120/240	362CSL1606	1	60	79/79	329	76/76	317	127
Stamford	600	UCI274C17	3	60	80/100	96	73/91	88	445
	277/480	UCI274C311	3	60	80/100	120	73/91	110	420
	120/208	UCI274C311	3	60	80/100	278	73/91	254	349
	120/240	UCI274C311	3	60	80/100	241	73/91	220	349
	120/240	UCI274C311	1	60	68/68	283	59/59	246	222
	120/240	UCI274C06	1	60	80/80	333	73/73	304	263



Engine Data

Manufacturer	Perkins
Model	1104D-E44TAG1
Aspiration	Turbocharged
EPA Tier	3
Charge Air Cooling System	Air-to-Air
Arrangement	Vertical Inline, 4-Cycle
Firing Order	1-3-4-2
Displacement: L (in. ³)	4.40 (268.50)
Bore: mm (in.)	105.00 (4.13)
Stroke: mm (in.)	127.00 (5.00)
Compression Ratio	16.2:1
BMEP: psi (kPa)	212.77 (1467.00)
Net Horsepower	121.67
Rated RPM	1800
Governor	Isochronous
Speed Regulation	±3.0%

Engine Liquid Capacity

Oil System: qt. (L)	8.45 (8.00)
Cooling System Capacity: gal (L)	4.49 (17.00)

Engine Electrical

Electric Volts: DC	12
Cold Cracking Amps	925
Battery(s) Required	1

Fuel System

Fuel Injection Type	Direct
Fuel Pump Rate: gal/hr (L/hr)	34.34 (130.00)
Pump Maximum Suction Head: in. H ₂ O (kPa)	68.23 (17.00)
Pump Maximum Pressure Head: in. H ₂ O (kPa)	40.13 (10.00)
Max Fuel Supply Restriction: in. H ₂ O (kPa)	160.53 (40.00)
Max Fuel Return Restriction: in. H ₂ O (kPa)	200.66 (50.00)
Recommended Fuel	Low Sulfur Diesel

Air Requirements

Air Filter(s) Type	Dry
Combustion Air Flow: CFM (m ³ /min)	271.92 (7.70)
Maximum Air Intake Restriction	
Clean: in. H ₂ O (kPa)	20.07 (5.00)
Dirty: in. H ₂ O (kPa)	32.11 (8.00)

Exhaust System

Gas Temperature: °F (°C)	917.6 (492.0)
Gas Flow: CFM (m ³ /min)	632.1 (17.9)
Max Exhaust Back Pressure: in. H ₂ O (kPa)	60.20 (15.00)
Exhaust Outlet Size: in. (mm)	2.52 (64.00)

Sound Level

Open Unit Without Exhaust: dBA 3.2 ft (1M)	105.5
--	-------

Filters and Quantity

Air Cleaner Quantity	1
Oil Filter(s) Quantity	1
Fuel Filter(s) Quantity	2

Fuel Consumption - 125°C

At 100% of Power Rating: gal/hr (L/hr)	6.26 (23.69)
At 75% of Power Rating: gal/hr (L/hr)	4.95 (18.74)
At 50% of Power Rating: gal/hr (L/hr)	3.58 (13.55)
At 25% of Power Rating: gal/hr (L/hr)	N/A

Fuel Consumption - 105°C

At 100% of Power Rating: gal/hr (L/hr)	N/A
At 75% of Power Rating: gal/hr (L/hr)	N/A
At 50% of Power Rating: gal/hr (L/hr)	N/A
At 25% of Power Rating: gal/hr (L/hr)	N/A

Cooling System

Rejection to Charge Cooler: kW (BTUM)	13.9 (790.5)
Rejection to Coolant & Oil: kW (BTUM)	53.6 (3048.2)
Coolant Flow: gal/min (L/min)	44.7 (169.0)

GENERAL GUIDELINES FOR DERATION: Altitude: Derate 0.5% per 100m (328 ft.) Elevation above 1000m (3279 ft.) Temperature: Derate 1.0% per 10°C (18°F) temperature above 25°C (77°F)

RATINGS: All three-phase units are rated at 0.8 power factor. All single-phase units are rated at 1.0 power factor.

125° RATINGS: 125° apply to installations served by a reliable utility source. The standby rating is applicable to varying loads for the duration of a power outage. There is no overload capability for this rating. Ratings are in accordance with ISO-3046/1, BS 5514, AS 2789, and DIN 6271.

105° RATINGS: 105° ratings apply to installations where utility power is unavailable or unreliable. At varying load the number of generator set operating hours is unlimited. A 10% overload capacity is available for one hour in twelve. Ratings are in accordance with ISO-8528/1, overload power in accordance with ISO-3046/1, BS5514, AS2789, and DIN 6271. For limited running time and base load ratings consult the factory. The generator set manufacturer reserves the right to change the design or specifications without notice and without any obligation or liability whatsoever.

Alternator Data

Manufacturer	Marathon
Type	PMG
Insulation NEMA Rise/Temp	NEMA H/125°C
Hertz	60
Phase	3
RPM	1800
Leads	12
Amortisseur Windings	Full
CFM Cooling Required	700
Voltage Regulator	PM500
Sensing	Three Phase
Voltage Regulation, No Load - Full Load	0.5%

Optional 0.25% Regulation DVR2000E+ Available

Features

- NEMA MG1-32, BS5000, and IEC 34-1 compliant; CE & CSA Certified and UL Listed
- Self-ventilated and drip proof construction
- Two-thirds pitch stator and skewed rotor
- Wet wound, epoxied field windings
- Designed to withstand overspeeds of up to 125%
- Hybrid analog/digital voltage regulator
- Under frequency protection
- Under frequency indication light
- Less than one cycle response time
- Over excitation protection
- Over excitation indication light
- Easy access front-panel adjustments
- Over voltage protection shutdown
- Analog input for paralleling

Alternator Data

Manufacturer	Stamford
Type	PMG
Insulation NEMA Rise/Temp	NEMA H/125°C
Hertz	60
Phase	3
RPM	1800
Leads	12
Amortisseur Windings	Full
CFM Cooling Required	1308
Voltage Regulator	MX341
Sensing	Single Phase
Voltage Regulation, No Load - Full Load	1.0%

Features

- BS EN 60034, BS5000, VDE 0530, NEMA MG1-32, IEC34, CSA C22.2-100, and AS1359 complaint
- IP23 enclosure
- Dynamically balanced to exceed BS6861:Part 1 Grade 2.5 vibration standard
- Quality assurance to BS EN ISO 9001
- Self-ventilated and drip proof construction
- Two-thirds pitch stator and skewed rotor
- Heavy duty bearings
- Fully guarded
- Overexcitation protection
- Under frequency protection
- Analog input
- Overvoltage protection
- Paralleling compatible
- Single-phase sensing



DGC2020 Digital Controller

- Integrated engine-genset control, protection, and metering
- Microprocessor allows for exact measurement, setpoint adjustment, and timing functions
- Front panel 3 position controls and indicators enable quick and simple operation
- Emergency stop push button and an Alarm Horn with silence button
- A wide temperature-range liquid crystal display (LCD) with backlighting
- SAE J1939 Engine ECU communications
- Remote RS-485 communications for Optional RDP-110 Remote Annunciator
- 4 programmable contact inputs and 10 contact outputs (2 ADC rated)
- Modbus Communications with RS-485, Battery Backup for Real Time Clock, UL recognized, CSA certified, CE approved, HALT (Highly Accelerated Life Tests) tested
- IP 54 Front Panel rating with integrated gasket and NFPA 110 Level 1 Compatible.
- Manual Override Keyswitch



Analog Controller with Emergency Bypass Key Switch

- Automatic CANBUS Engine Control
- Oil Pressure, Water Temperature, Battery Voltage and RPM Gauges
- Automatic Gauge Zeroing on Shutdown
- AC Voltage, Frequency, Percent of Load, and Run-Time Metering
- 3-Position Auto-Off-Manual Control Switch
- LED Status Lights: Low Oil Pressure, High Temperature, Overcrank, Overspeed, & Engine Start

Standard Features:

Warranty

2 Year Standard

5 Year Comprehensive

- Heavy Duty Steel Base
- Vibration Isolators
- Oil Drain Valve with Extension
- Battery Rack & Cables
- High Ambient Unit Mounted Radiator
- Battery Charging Alternator
- Factory Powder Coating
- Factory Test
- Owner's Manual

Controller Options

DGC-2020HD Controller

Fiber Optic Ethernet (DGC-2020HD)

RS-232 Port & Generator Protection (DGC-2020)

Flush or Surface Mount Remote Annunciator

Remote Mount Break Glass E-Stop Switch

Miscellaneous Options:

- Battery Charger
- Coolant Drain Kit
- Block Heater
- Line Circuit Breaker
- Pad Type Battery Heater
- Battery Heater Blanket w/Thermostat
- Oil Pan Heater
- Generator Strip Heater

Narrow Skid Base Open Unit

Options:

- Radiator Duct Flange
- Flex Exhaust
- Critical Silencer
- Wide Skid Base

OVERALL SIZE: 81"L x 30"W x 55"H
Approximate Weight: 2,100 lbs.

Note: Dimensions and weights reflect standard open unit with no options and are subject to change.

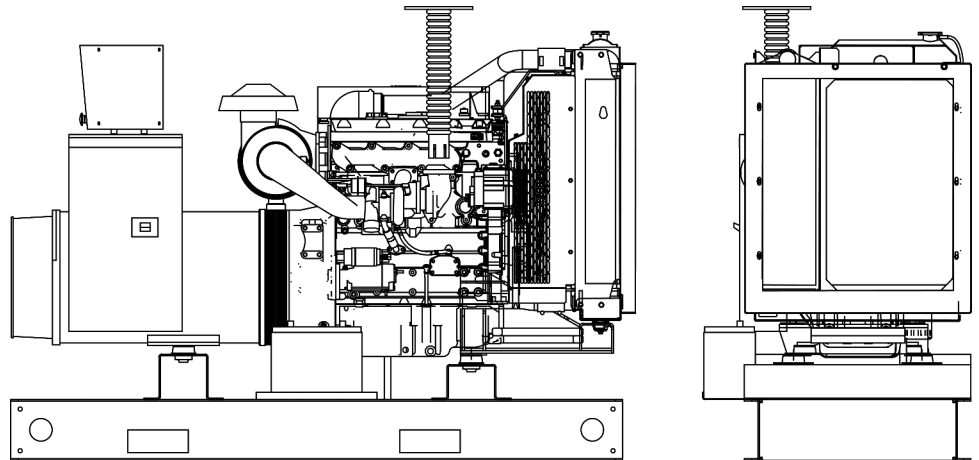

Standard Enclosed Unit

Options:

- Sound Attenuated Enclosure
- Load Center, Lights & GFI Receptacle
- Sub-Base Fuel Tank

OVERALL SIZE: 102"L x 46"W x 64"H
Approximate Weight: 3,100 lbs.

Note: Dimensions and weights reflect standard enclosed unit with no options and are subject to change.

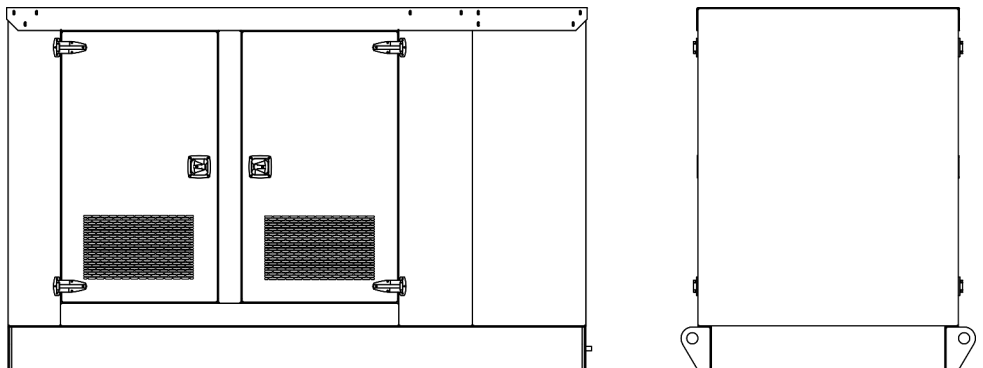

Note: The above drawings are provided for reference only and should not be used for planning installation.

Contact your local distributor for more information.