

MDG175DF4 | 6.8L | 140 kW

MOBILE DIESEL GENERATOR SET

EPA Emissions Certification: Tier IV Final

GENERAC® | MAGNUM

Standby Power Rating

173 kW, 217 kVA, 60 Hz

Prime Power Rating

140 kW, 175 kVA, 60 Hz



Image used for illustration purposes only

Codes and Standards

Generac Magnum products are designed to the following standards:



CSA



NATM



TIER 4 FINAL EMISSIONS



ISO 8528-5

Power When and Where You Need It

Generac Magnum mobile diesel generators are designed and engineered to power a variety of projects, in the most extreme environments. Gensets are configured to meet customer needs, including choice of containment, cold weather packages, trailer options, and more.

Generac Magnum mobile diesel generators are manufactured to deliver reliable power, when and where you need it.

STANDARD FEATURES

ENGINE SYSTEM

- John Deere® 6068HFG05 – turbocharged + after-cooled, diesel engine
- Six cylinder
- 415 in³ (6.8 L) displacement
- Tier IV Final (SCR + DOC)
- Rubber vibration dampers isolate engine/generator from frame
- Disposable air filter – paper element
- Variable Geometry Turbocharger (VGT)
- Electronic isochronous governing
- Variable speed fan drive

Fuel System

- Steel, double wall fuel tank
- 110% fluid containment
- 358 gal (1355 L) diesel tank capacity
 - 34 hr run time – full load
- Fuel tank built into skid of generator set
- 34.4 gal (130.4 L) DEF tank capacity
- Fuel consumption at prime:
 - 100% – 10.2 gph (38.5 Lph)
 - 75% – 8.4 gph (31.7 Lph)
 - 50% – 6.3 gph (23.7 Lph)
- DEF consumption rate:
 - 100% standby – 0.36 gph (1.4 Lph)

Cooling System

- Capable of operating at 120 °F (49 °C) ambient
- Low coolant shutdown
- Radiator and oil drains plumbed to exterior

SYSTEM OUTPUTS

- 3-position selector switch (lockable)
 - Single phase – 120 / 240V Zig Zag
 - Three phase – 120 / 208V Low Wye
 - Three phase – 277 / 480V High Wye
- 150 kW / 150 kVA – standby, single phase
- 138 kW / 138 kVA – prime, single phase
- 173 kW / 217 kVA – standby, three phase
- 140 kW / 175 kVA – prime, three phase

GENERATOR

- 60 Hz engine/generator
- Marathon Electric
 - Brushless
 - 4-pole
 - Class H insulation
- Voltage regulation ± 1.0% with PM600 Voltage Regulator

ENCLOSURE

- Aluminum, sound attenuated enclosure
 - UV and fade resistant, high temperature cured, white polyester powder paint

- Insulated and baffled
 - 75 dB(A) at 23 ft (7 m) – prime power
- Fully lockable enclosure including doors and fuel fill
- Emergency stop switch located on outside of enclosure
- Central lifting point
- Multi-lingual operating/safety decals
- Document holder with operating manual including AC/DC wiring diagrams

TRAILER

- DOT approved tail, side, brake, and directional lights; recessed rear lights
- Transportation tie downs
- Safety chains with spring loaded safety hooks
- 3 in. (76.2 mm) lunette ring hitch
- Two 8000 lb (3629 kg) axles with surge brakes
- 10000 lb (4536 kg) tongue jack with footplate
- ST215/75R17.5 tubeless tires – 10 ply

WARRANTY

- 1 year unlimited
- 2 years / 2000 hours

CERTIFICATIONS

- CSA certified

SYSTEM CONTROLS

Power Zone® Controller And Display

- Backlit, 800 x 480 pixel resolution color display
- -40 °F to 185 °F (-40 °C to 85 °C) operating temperature range
- Automatic coarse voltage adjustment
- Integrated fine voltage adjustment
- PLC functionality

Push Buttons For Easy Operation

- Manual or Auto Start
- Engine Start
- Engine Stop/Reset
- Alarm Mute
- Operator Screens
 - Home
 - Engine
 - Generator
 - Voltage Adjust

Scrolling Arrows for Diagnostic Information

- Engine diagnostic display
 - Oil pressure
 - Engine temperature
 - Fuel level
 - Battery
 - Aftertreatment inlet/outlet temperature
 - Ash/soot levels

- Generator diagnostic display
 - System kW output display
 - Line output and frequency display
- Alarms
 - Warning
 - Shutdown
 - Electrical Trip
 - Engine
- Alarm list – warnings/shutdowns; 250 event history log – date/time stamp
 - Fuel level: warning – 15%; shutdown – 5%
 - Overspeed protection: shutdown – 115%
 - Oil pressure: warning – 24 psi (165.5 kPa); shutdown – 19 psi (131 kPa)
 - Coolant temperature: warning – 230 °F (110 °C); shutdown – 235 °F (113 °C)
 - Battery voltage: over – 15VDC; under – 11VDC
 - Generator over voltage: warning – 110%; electrical trip – 125%
 - Generator under voltage: warning – 91%; electrical trip – 70%
 - Generator over frequency: warning – 102.5%; electrical trip – 110%
 - Generator under frequency: warning – 95%; electrical trip – 90%
- Inputs/Outputs
- Auto Schedule
- Status
- Configuration of controller, firmware, and connections

ELECTRICAL CONTROLS

- Remote start/stop contacts located in receptacle box
- Lockable control box door with diagnostics window
- Lockable lug box with safety switch
 - Trips main breaker when door is opened
 - Disables voltage regulator
- Output ground connection lug inside lug box
- 700A main breaker with shunt trip
- Convenience receptacles with individual breakers (restricted use in high wye mode)
 - Two 120V 20 amp GFCI duplex outlets – (NEMA 5-20R type)
 - Three 125/250V 50 amp, 3-pole, 4-wire Twist-lock (Non-NEMA 6369)
- Voltage adjustment integrated into Power Zone controller, ± 10%
- Two 12V / 1000 CCA wet cell batteries
- Battery disconnect switch

MDG175DF4 | 6.8L | 140 kW

MOBILE DIESEL GENERATOR SET

EPA Emissions Certification: Tier IV Final

GENERAC® | MAGNUM

OPTIONS

POWERTRAIN SYSTEM

- Block heater
- Fuel filter heater
- CCV heater
- 60/40 coolant
- Positive air shutdown
- Engine oil reservoir
- Cam locks
- 10A battery charger

TRAILER

- Full size spare tire
- Tool box/storage bin
- 2-5/16" (5.9 cm) ball hitch
- Electric brakes

CABINET

- Auxiliary fuel connection for day tank
- 36 hour tank
- Fire extinguisher

CONTROL SYSTEM

- 4-position selector switch
- PMG/DVR
- Paralleling
- Buck transformer



RATING DEFINITIONS

Standby - Applicable for varying emergency load for the duration of a utility power outage.

Prime - Applicable for supplying power to a varying load in lieu of utility for an unlimited amount of running time.

*Consult factory for availability

APPLICATION AND ENGINEERING DATA

ENGINE SPECIFICATIONS

General

Make	John Deere 6068HFG05
EPA Emissions Compliance	Tier IV Final
Aftertreatment System	SCR / DOC
Cylinder #	6
Type	In-line
Displacement	415 in ³ (6.8L)
Bore – in (mm)	4.19 (106.5)
Stroke – in (mm)	5.0 (127.0)
Compression Ratio	17.2:1
Intake Air Method	Turbo / Air to Air

Engine Governing

Governor	Electronic
Frequency Regulation (Steady State)	2%

Lubrication System

Oil Pump Type	Gear
Oil Filter Type	Spin-on cartridge
Crankcase Capacity – qts (L)	34.3 (32.5)

Cooling System

Cooling System Type	Pressurized Closed
Water Pump Type	Belt driven
Fan Type	Pusher
Fan Speed (rpm)	2190
Fan Diameter – in (mm)	28 (710)
Cooling System Capacity – gal (L)	11 (42)

Fuel System

Fuel Type	Ultra low sulfur diesel
Fuel Specifications	EN 590 / ASTM D975
Fuel Filtering (microns)	2
Fuel Inject Pump Make	Denso HP6
Fuel Pump Type	Engine driven – belt
Injector Type	Electronic
Engine Type	Direct inject
Fuel Supply Line – in (mm)	0.375 (9.5)
Fuel Return Line – in (mm)	0.375 (9.5)

Engine Electrical System

System Voltage	12VDC
Battery Charger Alternator	STD
Battery Size	1000 CCA
Battery Voltage	12V (2)
Ground Polarity	Negative

ALTERNATOR SPECIFICATIONS

Standard Model	432CSL6212
Poles	4
Field Type	Rotating
Insulation Class - Rotor	H
Insulation Class - Stator	H
Total Harmonic Distortion	< 5%
Telephone Interference Factor (TIF)	< 50

Standard Excitation	Brushless
Bearings	Double shielded, pre-lubricated
Coupling	Direct, Flexible Disc
Prototype Short Circuit Test	Yes
Voltage Regulator Type	AVR
Number of Sensed Phases	1
Regulation Accuracy (Steady State)	± 1%

OPERATING DATA

POWER RATINGS

	Standby		Prime	
Single-phase, 120/240VAC @ 1.0pf (kW/kVA)	150 kW / 150 kVA	Amps: 625*	138 kW / 138 kVA	Amps: 575*
Three-phase, 120/208VAC @ 0.8pf (kW/kVA)	173 kW / 217 kVA	Amps: 611	140 kW / 175 kVA	Amps: 468
Three-phase, 120/240VAC @ 0.8pf (kW/kVA)	173 kW / 217 kVA	Amps: 522	140 kW / 175 kVA	Amps: 421
Three-phase, 277/480VAC @ 0.8pf (kW/kVA)	173 kW / 217 kVA	Amps: 265	140 kW / 175 kVA	Amps: 210

* Circuit breaker limited

STARTING CAPABILITIES (sKVA)

	sKVA vs. Voltage Dip	
	208 VAC	480 VAC
SuperStart	22%	20%

FUEL CONSUMPTION RATES*

Percent Load	Diesel - gal/hr (l/hr)	
	Standby	Prime
25%	4.1 (15.5)	3.8 (14.4)
50%	6.7 (25.4)	6.3 (23.8)
75%	9.2 (34.8)	8.4 (31.8)
100%	12.3 (46.6)	10.2 (38.6)

Deration – Operational characteristics consider maximum ambient conditions. Derate factors may apply under atypical site conditions. Please consult a Generac Mobile Products Authorized Service Dealer for additional details. All performance ratings in accordance with ISO3046, BS5514, ISO8528, ISO8665, ISO3046, SAE J1228, SAE J1995, and DIN6271 standards.

DIMENSIONS AND WEIGHTS*

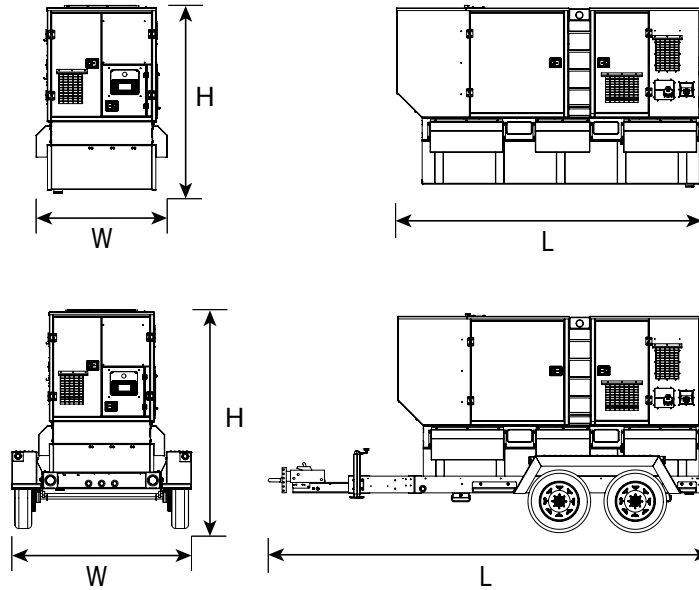

	Run Time Hours	Usable Capacity Gal (L)	L x W x H in (m)	Weight lbs (kg)
Skid	34	343 (1297)	145 (3.7) x 60 (1.5) x 85 (2.1)	Dry: 9070 (4114) Operating: 11900 (5397)
Trailer	34	343 (1297)	208 (5.3) x 86 (2.2) x 104 (2.6)	Dry: 10470 (4749) Operating: 13300 (6032)

* All measurements are approximate and for estimation purposes only.

YOUR FACTORY RECOGNIZED GENERAC MOBILE PRODUCTS DEALER

Specification characteristics may change without notice. Dimensions and weights are for preliminary purposes only. Please consult a Generac Mobile Products Authorized Service Dealer for detailed installation drawings.