

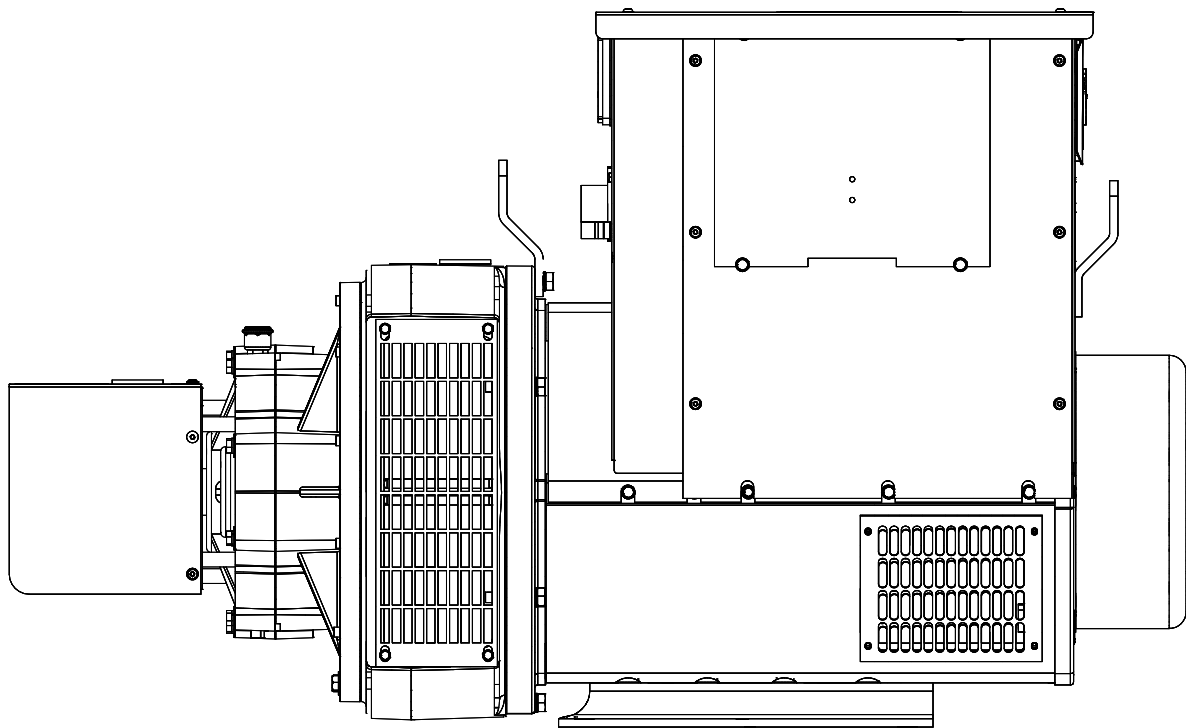

# W70PTO & W70PTOS 70PTOT4 & 80PTOT4 GENERATORS

# INSTALLATION AND OPERATORS MANUAL



COPY YOUR MODEL AND SERIAL NUMBER HERE  
No other WINCO generator has the same serial number as yours.  
If you should ever need to contact us concerning this unit, it will help us to respond to your needs faster.

MODEL \_\_\_\_\_

SERIAL NUMBER \_\_\_\_\_

PURCHASE DATE \_\_\_\_\_

DEALER NAME \_\_\_\_\_

DEALER PHONE # \_\_\_\_\_

# TABLE OF CONTENTS

## SAVE THESE INSTRUCTIONS

### SAFETY

IMPORTANT SAFETY INSTRUCTIONS

### SPECIFICATIONS

### INTRODUCTION

TESTING POLICY

### PREPARING THE UNIT

UNPACKING

### INSTALLATION

FOUNDATION MOUNTING

TRAILER MOUNTING

### ELECTRICAL CONNECTIONS

Typical Connection Methods for Generator Power Service

### OPERATION

### PRE-START CHECKS

### GENERATOR PROCEDURES

START UP

SHUTDOWN

### MAINTENANCE

GENERAL

PERIODICAL MAINTENANCE

LUBRICATION

CLEANING & INSPECTION

GENERATOR STORAGE

### TROUBLE SHOOTING TABLES

### WIRING DIAGRAMS

### WARRANTY STATEMENT

# SAVE THESE INSTRUCTIONS

**2**

**3**

**4**

**5**

**5**

**6**

**7**

**9**

**9**

**10**

**11**

**13**

**14**

**18**

This manual contains important instructions that should be followed during installation and maintenance of the generator. Read and understand all instructions in the manual before starting and operating the generator. Keep this manual available for future reference.

#### USING THIS MANUAL

Congratulations on your choice of a WINCO generator. You have selected a high-quality, precision-engineered generator designed and tested to give you years of satisfactory service.

To get the best performance from your new generator, it is important that you carefully read and follow the operating instructions in this manual.

Should you experience a problem please follow the "Troubleshooting Tables" near the end of this manual.

The warranty listed in the manual describes what you can expect from WINCO should you need service assistance in the future.

# SAFETY

## IMPORTANT SAFETY INSTRUCTIONS

This engine generator set has been designed and manufactured to allow safe, reliable performance. Poor maintenance, improper or careless use can result in potentially deadly hazards; from electrical shock, or fire. Please read all safety instructions carefully before installation or use. Keep these instructions handy for future reference. Take special note and follow all warnings on the unit labels and in the manuals.

## SAFETY DEFINITIONS

<b>DANGER</b>	Indicates an imminently hazardous situation which, if not avoided, <b>will</b> result in death or serious injury.
<b>WARNING</b>	Indicates a potentially hazardous situation which, if not avoided, <b>could</b> result in death or serious injury.
<b>CAUTION</b>	Indicates a potentially hazardous situation which, if not avoided, <b>may</b> result in minor or moderate injury. It may be used to alert against unsafe practices.

### CALIFORNIA PROPOSITION 65



**WARNING:** This product contains crude oil, gasoline, diesel fuel and other petroleum products, Antifreeze to which can expose you to chemicals including toluene and benzene, Ethylene glycol (ingested) which are known to the State of California to cause cancer, birth defects or other reproductive harm and developmental issues. For more information go to [www.P65Warning.ca.gov](http://www.P65Warning.ca.gov).

### DANGER: ELECTRIC SHOCK

The output voltage present in this equipment can cause a fatal electric shock. This equipment must be operated by a responsible person.

- A. Do not allow anyone to operate the generator without proper instruction.
- B. Guard against electric shock.
- C. Avoid contact with live terminals or receptacles.
- D. Use extreme care if operating this unit in rain or snow.
- E. Use only three-prong grounded plugs and extension cords.
- F. Be sure the unit is properly grounded to an external ground rod driven into the earth.

### WARNING: FIRE HAZARD

Keep a fire extinguisher nearby and know its proper use. Fire extinguishers rated ABC by NFPA are appropriate.

### CAUTION: NOISE HAZARD

Excessive noise is not only tiring, but continual exposure can lead to loss of hearing.

- A. Use hearing protection when working around this equipment for long periods of time.
- B. Keep your neighbors in mind when permanently installing this equipment.

### CAUTION

Keep the generator and surrounding area clean.

- A. Remove all grease, ice, snow or materials that create slippery conditions around the unit.
- B. Remove any rags or other materials that could create a potential fire hazard.
- C. Carefully clean up any gas or oil spills before starting the unit.

### CAUTION

All service, including the installation or replacement of service parts, should be performed only by a qualified technician.

- A. Use only factory approved repair parts.
- B. Do not work on this equipment fatigued.
- C. Use extreme caution when working on electrical components. High output voltages from this equipment can cause serious injury or death.
- D. Installing a generator is not a "do-it-yourself" project. Consult a qualified, licensed electrician or contractor. The installation must comply with all national, state, and local codes.

### WARNING

Installing a PTO generator is not a "do-it-yourself" project. Consult a qualified, licensed electrician or contractor. The installation must comply with all national, state, and local codes.

- A. Never operate the PTO drive generator without having it properly mounted to a concrete base or approved trailer.
- B. Never connect the PTO generator to an existing electrical system without installing an isolation transfer switch.
- C. Always insure the drive shaft is straight and level before operating the generator.

### WARNING

PTO drive shafts (tumbling bars) have many inherent dangers, extreme caution must be exercised when using them.

- A. NEVER allow children around the drive shaft when it is in operation.
- B. Keep all safety guards and shields in place and securely tightened.
- C. Never operate a drive shaft that has been damaged or had the safety shield removed.
- D. Never step over a drive shaft while it is running.
- E. Never wear a necktie, loose articles of clothing, or anything else that can be caught in moving parts.
- F. Never try to stop drive shaft with your hand or your foot.

# SPECIFICATIONS

---

## GEAR LUBE

Volume	0.875 Pint (gray models) 1.0 Pint (red models)
Type	SAE 80-90W-140

## W70PTO

Continuous Watts	69,000
Volts	120/240
Phase	Single
Amps	287
Power Factor	1.0
Input Speed	540 RPM
Generator Speed	1800 RPM
Input Shaft	1 3/4" - 20 Spline
Required Tractor PTO HP	138

## W70PTOS

Continuous Watts	69,000
Volts	120/240
Phase	Single
Amps	287
Power Factor	1.0
Input Speed	1000 RPM
Generator Speed	1800 RPM
Input Shaft	1 3/4" - 20 Spline
Required Tractor PTO HP	138

## 70PTOT4-03

Continuous Watts	69,000
Volts	120/240
Phase	Single
Amps	287
Power Factor	1.0
Input Speed	1000 RPM
Generator Speed	1800 RPM
Input Shaft	1 3/8" - 6 Spline
Required Tractor PTO HP	138

## 70PTOT4-04

Continuous Watts	71,000
Volts	120/208
Phase	Three
Amps	246
Power Factor	0.8
Input Speed	1000 RPM
Generator Speed	1800 RPM
Input Shaft	1 3/8" - 6 Spline
Required Tractor PTO HP	142

## 70PTOT4-17

Continuous Watts	71,000
Volts	120/240
Phase	Three
Amps	213
Power Factor	0.8
Input Speed	1000 RPM
Generator Speed	1800 RPM
Input Shaft	1 3/8" - 6 Spline
Required Tractor PTO HP	142

## 80PTOT4-18

Continuous Watts	80,000
Volts	277/480
Phase	Three
Amps	120
Power Factor	1.0
Input Speed	1000 RPM
Generator Speed	1800 RPM
Input Shaft	1 3/8" - 6 Spline
Required Tractor PTO HP	160

## 80PTOT4-21

Continuous Watts	79,000
Volts	346/600
Phase	Three
Amps	95
Power Factor	0.8
Input Speed	1000 RPM
Generator Speed	1800 RPM
Input Shaft	1 3/8" - 6 Spline
Required Tractor PTO HP	158

# INTRODUCTION

## TESTING POLICY

Before any generator is shipped from the factory, it is fully checked for performance. The generator is loaded, and the voltage, current, and frequency are carefully checked.

Rated output of generator is based on engineering tests of typical units, and is subject to, and limited by, the temperature, altitude, fuel, and other conditions specified by the manufacturer of applicable engines.

The WINCO power take-off generators are designed primarily for farm use as a standby electrical power supply, utilizing the power take-off of a tractor or truck as the prime mover. This PTO drive generator will provide, 120/240V 1-PH, 120/208V 3-PH, 120/240V 3-PH, or 277/480V 3-PH (depending on model), 60Hz electrical service when properly driven.

**DO NOT** operate and/or store the unit outside during inclement weather without adequate protection from the elements. Failure to do so will damage the unit.

It is acceptable to use this generator with a tractor with less HP output than required for full power operation. The generator will work but produce only as much kW output as the tractor can supply HP for. For example, a 20 HP output tractor will deliver a maximum of approximately 10 kw.

If you are using a tractor with more HP than required to run the generator care should be taken to ensure that you do not overload the generator causing overheating and equipment damage. Observe input RPM specifications.

The generator may be foundation mounted for use as standby power source, or trailer mounted, and used as portable electrical power sources for areas where commercial power is not readily available, such as out buildings.

This generator includes a frequency meter to warn against high or low frequency, three output power receptacles, an overload protection circuit, and an electronic excitation circuit. To reduce maintenance problems, the coupling between the generator input shaft and rotor consists of precision helical gearing rather than a chain link drive. The input shaft is a 1 3/4in. 20-spline or 1 3/8in. 6-spline, depending on the model.

**IMPORTANT: THE MANUFACTURER STRONGLY RECOMMENDS RUNNING THE GENERATOR UNDER LOAD AT LEAST ONCE A MONTH IN ORDER TO EVAPORATE ANY ACCUMULATED MOISTURE CONDENSATION.**

# PREPARING THE UNIT

## UNPACKING

### CAUTION: EQUIPMENT DAMAGE

When you unpack your new generator, be sure to remove all of the information sheets and manual from the carton.

1. As you receive your unit, it is critical to check it for any damage. If any damage is noted, it is always easiest to refuse the shipment and let WINCO take care of the freight claim. If you sign for the unit, the transfer of the ownership requires that you file the freight claim
2. Before proceeding with the preparations of your new generator for operation, take a couple of minutes to ensure the unit you have received is the correct model and review the specification pages in this manual to ensure that this unit meets your job requirements.

# INSTALLATION

Note: PTO mounting holes are .75”.

## FOUNDATION MOUNTING

Mount the generator on a foundation if it is to be used as a permanent or standby power source. When planning a foundation, consider the following points:

- A. The foundation location should enable aligning the drive shaft (tumbling bar) in a straight or nearly-straight line between the power take-off and the generator input shaft. Misalignment must be less than 15 degrees during generator operation, even though the mechanical design of the tumbling bar may allow greater misalignment.
- B. The foundation must be solid enough to absorb generator starting and reflected load torque during operation.
- C. The foundation surface should be flat.
- D. Space is required around the generator for mounting switching devices, making connections, and for servicing.
- E. For dimensions needed for your specific generator, please refer to it's outline drawing. The hardware needed is dependent on your distinct application.
- F. All four generator mounting pads must rest firmly on the foundation. Install shims if necessary to even out the foundation under the mounting pads, then bolt the generator firmly in place.

## WARNING: PERSONAL INJURY & EQUIPMENT DAMAGE

Trailer may tip over and cause injuries if wheels are not spaced far enough apart.

- C. The trailer height and mounting position of the generator on the trailer should enable aligning the drive shaft (tumbling bar) in a straight or nearly straight line between the power take-off and generator input shafts. Misalignment must be less than 5 degrees during generator operation, even though the mechanical design of the tumbling bar would allow greater misalignment.
- D. The generator mounting area of the trailer bed should be flat. All four generator mounting pads must rest firmly on the trailer bed. Install shims if necessary to even out the bed under the mounting pads, then bolt the generator firmly in place.

## TRAILER MOUNTING OPTIONAL

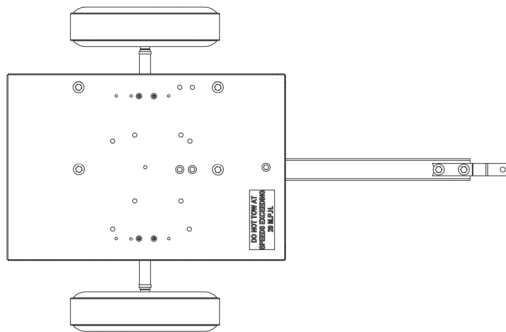

Mount the generator on a trailer if you plan to use it as a portable power source. When selecting or building a trailer to mount the generator, consider the following points:

- A. The trailer construction must be strong enough to support the generator.
- B. The design of the trailer must enable the trailer to remain stable during operation, and to resist tipping caused by generator starting and reflected load torque.

# ELECTRICAL CONNECTIONS

## CAUTION:

Only qualified electricians should install electric wiring. Wiring must conform to all applicable national, state, and local codes. (Reference: National Fire Protection Association Manual No. 70, National Electrical Code.)

## DANGER: PERSONAL INJURY

If the generator is to be used as a standby power source, a special disconnect switch must be installed to separate the generator and the commercial power lines. The disconnect must isolate the generator from the commercial power lines and the load when the generator is on standby, and must isolate the commercial power lines from the load and generator when the generator is supplying power.

A properly rated and installed double throw manual power isolation transfer switch must be used with a standby generator. The transfer switch isolates the load from the power line and allows you to safely operate your loads without endangering the power line repair crew.

The load, connected to the normal terminals of the transfer switch, is energized by the normal power line when the switch is in the normal position. The generator, connected to the emergency terminals of the switch, furnishes power when the switch is in the emergency mode position.

There are two ways to install a manual transfer switch. The first is to install the switch between the watt-hour meter and the normal distribution panel. As with any system you must install an entrance rated breaker before the manual transfer switch. The manual transfer switch must in all cases be equal to or greater than the rating of the entrance rated breaker.

The second way to install the system is to purchase and install an emergency distribution panel and move the circuits you wish to back up to the new distribution panel. In this case the manual transfer switch only has to be sized to the amperage of the circuit breaker in the main distribution panel that is feeding it.

Before deciding which system to install, first determine which loads you can safely run on your PTO generator and the cost of buying a large manual transfer switch versus the cost of a smaller switch and the additional distribution panel.

The only assembly work required after unpacking the generator is to assemble the load disconnect plug, which is contained in a bag in the sub-pack carton packed in the generator crate.

The bag contains an instruction sheet, 2 plug bodies, four contacts, a handle and the hardware to assemble the disconnect plug. You will need to purchase the appropriate length of fine stranded copper wire for your application in order to complete the assembly of the disconnect plug.

VOLTAGE	RECOMMENDED WIRE	CONTACTS INCLUDED
120/240 1-PH	3/0	3/0
208/240 3-PH	1/0	1/0 to #1
277/480 3-PH	#4	#2 & #4

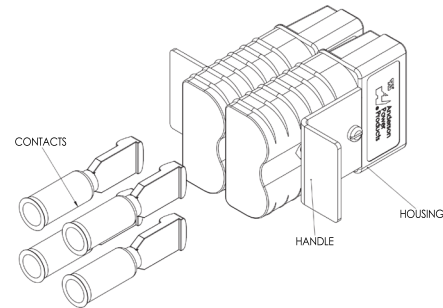

## WARNING: EQUIPMENT DAMAGE

Never use acid core solder. When soldering insure no excess solder runs down on the contact surface - Solder on the contact surface will not allow the contacts to mate properly causing them to burn up.

Each wire should be stripped back 7/8 of an inch and inserted into one of the contacts in the plug kit. You will then either need to solder them together using a good grade of resin core solder or they can be crimped with an appropriate compression crimper or both.

Approved crimping tools are:

1. Anderson Power Products
2. ETC Model HHS hydraulic crimper
3. ITT Blackburn No. 1640
4. Thomas & Betts #TBM5

To complete the assembly of the disconnect plug refer to the instruction sheet in the plug kit.

## WARNING: ELECTRICAL SHOCK

During the next step, the load disconnect plug should not be plugged into its receptacle. Also, make sure that the equipment to which the plug leads (cables) are being connected is not energized (live).

Strip the insulation off of the free end of each of the plug leads (cables) and connect them to the load transfer switch or directly to the load.

# TYPICAL CONNECTION METHODS FOR GENERATOR POWER SERVICE

**IMPORTANT:** When making standby service hook up, make sure load to be transferred to standby generator will not exceed generator rating.

TYPICAL HOOK UP FOR SUPPLYING ALL CIRCUITS WITH EMERGENCY POWER

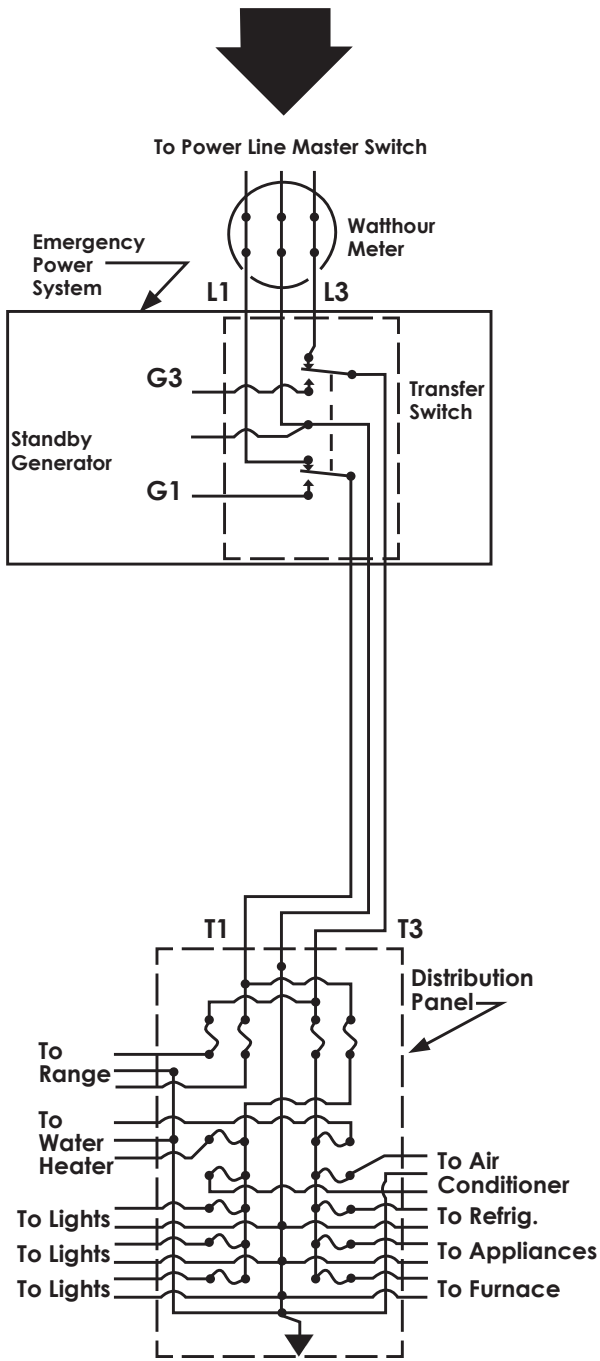

TYPICAL HOOK UP FOR SUPPLYING ONLY ESSENTIAL CIRCUITS WITH EMERGENCY POWER

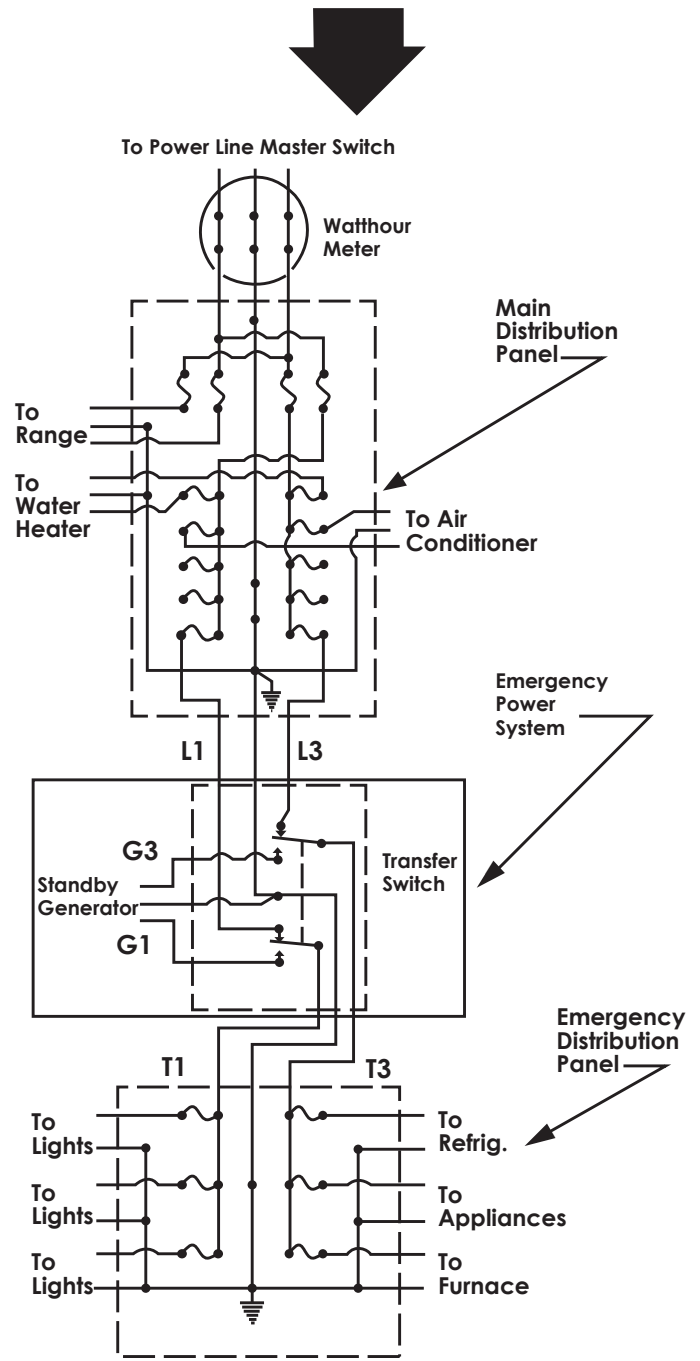



# OPERATION

## OUTPUT POWER AVAILABLE AND LOAD DETERMINATION

Before using the generator, read and understand the following information.

Generator output current (amperage) is internally limited by three circuit breakers. If too much demand is placed on a generator output (if you try to drive too many motors with it, for example), one of the circuit breakers will trip, cutting off the output in order to protect the generator.

A 20 Amp push-to-reset circuit breaker protects the 120V duplex receptacle output circuit. 20 Amps is the total limit for both outputs of the duplex receptacle.

A large switch type main circuit breaker protects the generator windings and output circuits, including the load disconnect receptacle outputs. The load disconnect receptacle is the largest gray receptacle on the generator output panel.

To aid in determining how much load can be applied to the generator, and how it should be distributed among the generator output receptacles, the following formulas may be useful. Get load voltages, current, and wattage from the nameplates on the equipment in the load.

Load current (in Amps) x Load voltage = Load wattage  
Amps x Volts = Watts  
Watt/1000 = kW

Load wattage / Load voltage = Load current (in Amps)

Example: 250W, 120V floodlight load:  $250W / 120V = 2$  Amps

### NOTE:

Electric motors require more current to start than to run. Commonly, the current rating given on a motor nameplate is the full load (running) current required by the motor, not its starting current, which is a lot higher. Motor starting current requirements vary greatly, by motor size and type. Repulsion-induction type motors are the easiest to start, typically using 1 1/2 to 2 1/2 times as much current to start as to run. Capacitor type motors usually require 2 to 4 times as much current to start as to run. Split-phase type motors are the hardest to start, normally using 5 to 7 times as much current to start as to run.

# PRE-START CHECKS

## WARNING: PERSONAL INJURY:

When working on or around these generators, do NOT wear loose fitting clothing or any articles that may get caught in moving parts.

1. Visually inspect the generator. Check for:
  - a. Correct mounting.
  - b. Physical damage.
  - c. Debris in cooling vents and screens. (Could cause generator to overheat)

## IMPORTANT:

The manufacturer recommends that, if the generator has been stored for any length of time, before using it, the operator remove the control box cover and cooling fan screen, then inspect the generator for rodent nests or other objects that could cause generator binding and/or overheating. See 'Cleaning' portion of the Maintenance section.

2. Check Gearcase oil level. (See drawing) Case should be filled with oil to plug marked 'OIL LEVEL'. Fill or remove oil as required.

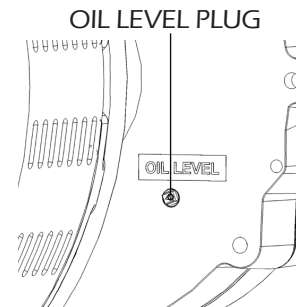

NOTE: Either too little or too much oil can harm the equipment.

See 'Lubrication' portion of Maintenance for oil specifications.

3. Make sure the drive shaft (tumbling bar) is assembled with its universal joint knuckles "synchronized," as illustrated below. If knuckles are not synchronized, the bar will chatter when rotating, which will cause the generator output voltage to flicker. Drive shafts shipped new from WINCO are always synchronized and tethered so they can not be taken apart.

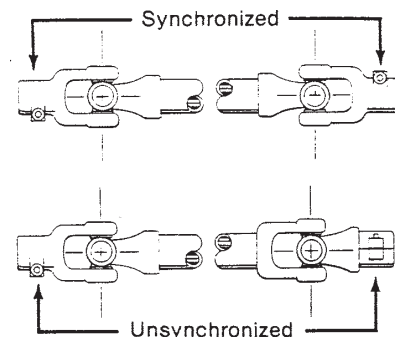

**DANGER: PERSONAL INJURY:**

Power take-off must be disengaged at this time.

4. Couple the tractor to the generator with the drive shaft (tumbling bar). Couple the tumbling bar to the generator input shaft first, then to the power take-off shaft. Check alignment, tractor, power take-off shaft (tumbling bar), and generator input shaft should form a straight (or nearly straight) line, with less than 5° misalignment between the tractor and generator input shafts. Misalignment will cause generator output voltage to flicker.

**WARNING: PERSONAL INJURY:**

Make sure that all tumbling bar lock pins are engaged and that all safety shields are in place before operating the PTO generator.

5. Make sure no binding exists in generator or gear box. If binding is found, locate the cause and correct it before proceeding.
6. Make sure that the electrical loads to be driven by the generator will not draw more current than the ratings of the generator receptacle or cord set which will supply the current.
7. Check all electrical connections in the system to be energized by the generator. Make sure the connections are correct and are tight.
8. Make sure all loads are turned off. Do not start the generator under load.

## **GENERATOR PROCEDURES**

### **START UP**

1. Set the manual transfer to mid or normal (up) position.
2. With the power take-off drive disengaged, start the engine which will drive the generator. Run the engine long enough to warm it up before proceeding, so that it will run smoothly and achieve full power under generator load.
3. With the engine idling, engage the power take-off drive.
4. Watch the frequency meter on the generator and slowly increase engine speed until the output reaches approximately 62 Hz for full loads.
5. Plug load cord set into receptacle. Place transfer switch in the emergency position.
6. Place the load circuit breaker in the "on" position. If the breaker trips, move manual transfer switch to "off" or normal position. Check for short circuit or grounded connection in the load cable to the double throw switch and repair. A breaker that trips from overload or short circuit must be reset by moving to "off" before re-closing.
7. With engine and generator running smoothly, switch on the electrical load while watching the frequency meter. Adjust engine throttle to keep generator output under load at 60 Hz. If engine is equipped with speed governor, it may automatically readjust the throttle as the load changes and keep the generator output at the proper level. However, some governors are not sensitive enough to maintain proper output under changing load, and in such cases the throttle will have to be manually readjusted.

**NOTE: EQUIPMENT DAMAGE**

If the load includes motors, turn them on one at a time, highest starting current motor first, next highest second, etc.

### **SHUTDOWN**

1. Switch off electrical load.
2. Reduce Speed of engine driving generator to idle.
3. Disengage power take-off drive, and allow generator to coast to a stop.

**WARNING: PERSONAL INJURY**

Never try to stop the generator. Always let it coast until it stops.

4. Shut off the engine.
5. Disconnect the drive shaft (tumbling bar) power take-off end first, then the generator end.

# MAINTENANCE

## GENERAL

The main components of the generator are: rotor and stator assembly, cooling fan, brushes, brush holder assembly, end brackets. Before performing any maintenance on the generator, isolate and/or disable the drive system so the unit can not be accidentally started while being repaired.

The trouble shooting chart lists various symptoms of poor generator operation with possible causes and the appropriate corrective action. You will need a volt-ohm meter or test light to check some of the causes. For some of the other causes you will need to check generator speed. To check generator speed, you can use a frequency meter, a tachometer, or a 120V-60Hz electric clock and a correctly operating wrist watch (run the electric clock and a correctly power and compare the clock's second hand movement with that of the wrist watch. They should run at the same speed. If the clock runs faster, generator speed is too high, and vice versa).

### CAUTION: EQUIPMENT DAMAGE

Most electrical equipment in North America operates satisfactory at frequencies between 58.5 and 62 Hz (cycles per second). Operating the generator at frequencies outside that range may cause damage to the generator and/or to electrical equipment driven by the generator.

## PERIODICAL MAINTENANCE

Service/maintenance items include periodic external physical inspection for missing hardware or damage to mounting or drive system and checking the oil level in the gearcase. It is recommended that the generator be operated at least monthly under normal loads to familiarize operators with the procedures and controls as well as to dry out any accumulated condensation or other moisture in the generator electrical windings. The maintenance and service attention invested will ensure getting the peak performance that was designed to the unit.

Routine preventative maintenance minimizes costly repairs and generator down-time. Before each use, inspect the generator: gearcase oil level should be correct, cooling vents and screens should be clear, and generator mounting hardware should be tight. Clean and inspect the generator after storing it for long periods, and after using it in extremely dusty conditions or in severe weather, such as rain or blowing snow.

## LUBRICATION

The generator bearings are factory lubricated and sealed, and require no further lubrication.

The splined generator input shaft should be cleaned and lubricated with a thin film of grease before and after each use of the generator.

The drive shaft (tumbling bar) requires greasing. Keep the universal joints in the coupling shaft free from grease and dirt buildup.

NOTE:

Do not over lubricate the universal joints.

See following illustration for recommended lubrication schedule for the coupling shaft.

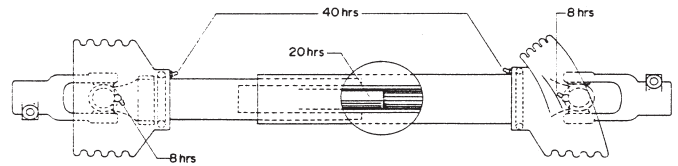

Check the generator gear case oil level before each use of the generator. Maintain the oil level at oil level plug height. The generator is shipped with lubricant in the gearcase. Specifications for the gearcase lubricant are:

API Service: GL-5  
Grade: SAE 80-90W-140  
Amount: 1 Pint (older red models)  
0.875 Pints (new gray models)

### CAUTION: EQUIPMENT DAMAGE

Do not overfill generator gearcase. Overfilling causes overheating and oil seal failure.

Change the oil at least once every six months. Change it more often if you use the generator in bad weather. Use the following procedure to change the generator gearcase oil.

1. Remove gearcase breather. Soak breather in cleaning solvent, then allow to dry.
2. Remove oil level plug. See illustration.

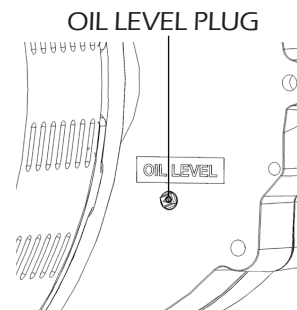

3. Remove the oil drain plug, drain the oil into a clean oil resistant container, 1 quart or larger. Check the oil for metal. Fine metal dust in the oil does not indicate trouble, but metal chips do. Dismantle the gearcase and look for damaged gears if you find metal chips in the oil.
4. Replace the oil drain plug. Refill the gearcase through the breather port with new oil of the recommended type. Fill the case up to the oil level check plug height. About 1 pint.
5. Replace the oil level check plug.
6. Replace the breather.

## **CLEANING & INSPECTION**

Use a vacuum cleaner or dry low pressure compressed air (regulated at 25-35 PSI) to clean the generator periodically.

### **WARNING:**

Do NOT clean the generator while it is running.

Proceed as follows:

1. Remove control box cover. Vacuum or blow dust or debris from the control box. Inspect all wiring for correct routing, fraying insulation, and secure connections.
2. Remove end cover. Vacuum or blow dust and debris from the inside of the generator. Inspect wiring for loose connections, fraying insulation and correct wire routing.
3. Replace end cover and control box cover.

## **GENERATOR STORAGE**

Before storing the generator, apply a heavy coat of grease to the splined input shaft. Store the generator in a sheltered area, where it is protected against snow, rain, and excessive dust.

# TROUBLE SHOOTING TABLES

SYMPTOM	CAUSE(S)	CORRECTIVE ACTION
No output voltage	<ol style="list-style-type: none"> <li>1. Circuit breaker open</li> <li>2. Defective frequency meter</li> <li>3. Short circuit in the load</li> <li>4. Defective receptacles</li> <li>5. Loose (or broken) wires or connections in control box</li> <li>6. Defective rotating rectifier</li> <li>7. Defective AVR</li> <li>8. Shorted or open rotor</li> <li>9. Shorted or open stator</li> </ol>	<ol style="list-style-type: none"> <li>1. Reset circuit breakers, replace if defective</li> <li>2. Check output with another meter, replace meter if defective.</li> <li>3. Disconnect the load. Check voltage at receptacle cord set. Check motors, appliances, and load leads for short circuit. Repair short.</li> <li>4. Remove panel cover and check for voltage to the receptacles. Replace defective receptacles.</li> <li>5. Remove panel cover and check all wiring and connections. Tighten and/or repair where necessary.</li> <li>6. Test rectifier. Replace if defective.</li> <li>7. Repair or replace as required.</li> <li>8. Measure rotor resistance. Replace rotor if open or shorted.</li> <li>9. Measure between leads for open or short. Replaces stator if defective.</li> </ol>
High voltage	<ol style="list-style-type: none"> <li>1. Engine speed too fast.</li> <li>2. Defective or misadjusted AVR</li> </ol>	<ol style="list-style-type: none"> <li>1. Check engine speed for correct input RPM</li> <li>2. Adjust, repair, or replace as required</li> </ol>
Low voltage	<ol style="list-style-type: none"> <li>1. Engine speed too slow</li> <li>2. Generator overloaded</li> <li>3. Inadequate engine horsepower.</li> <li>4. Defective or misadjusted AVR</li> </ol>	<ol style="list-style-type: none"> <li>1. Check engine speed. Increase RPM if necessary.</li> <li>2. Reduce load if it is higher than the rated capacity of the generator. (see generator nameplate)</li> <li>3. Generator requires 2 HP/1000 watt output. Obtain larger engine if necessary.</li> <li>4. Repair, adjust, or replace as required.</li> </ol>
Output voltage flickering or fluctuation	<ol style="list-style-type: none"> <li>1. Tumbling bar (shaft) misalignment</li> <li>2. Engine governor may be worn or improperly adjusted. Set or repair defective governor.</li> <li>3. Loose connection in field circuit</li> <li>4. Tumbling bar U-Joints not synchronized</li> </ol>	<ol style="list-style-type: none"> <li>1. Reduce tumbling bar misalignment to less than 15 degrees</li> <li>2. Engine governor may be worn or improperly adjusted. Set or repair defective governor.</li> <li>3. Check and tighten connections.</li> <li>4. Reassemble tumbling bar.</li> </ol>
Excessive vibration	<ol style="list-style-type: none"> <li>1. Power take-off misalignment excessive</li> <li>2. Loose mounting nuts and bolts or hold down studs</li> <li>3. Universal joints in coupling shaft worn or dry.</li> <li>4. Defective bearings</li> </ol>	<ol style="list-style-type: none"> <li>1. Correct misalignment. It should be less than 15 degrees.</li> <li>2. Tighten mounting butts and bolts; repair hold down stud mountings.</li> <li>3. Repair or replace defective parts.</li> <li>4. Check for possible causes. Replace defective bearings.</li> </ol>
Generator overheating	<ol style="list-style-type: none"> <li>1. Poor ventilation</li> <li>2. Generator overloaded</li> <li>3. Shorted turns in field or stator windings.</li> </ol>	<ol style="list-style-type: none"> <li>1. Clean ventilation and cooling fan screens.</li> <li>2. Reduce load, then check voltage and current.</li> <li>3. Replace defective components.</li> </ol>
Oil Leak	<ol style="list-style-type: none"> <li>1. Loose plug in gearcase</li> <li>2. Defective seal, gasket, or plug in gearcase</li> </ol>	<ol style="list-style-type: none"> <li>1. Tighten plug.</li> <li>2. Replace seal(s), gaskets or plugs. Maintain correct oil level.</li> </ol>

# WIRING DIAGRAMS

**W70PTO & W70PTOS**  
BACK VIEW

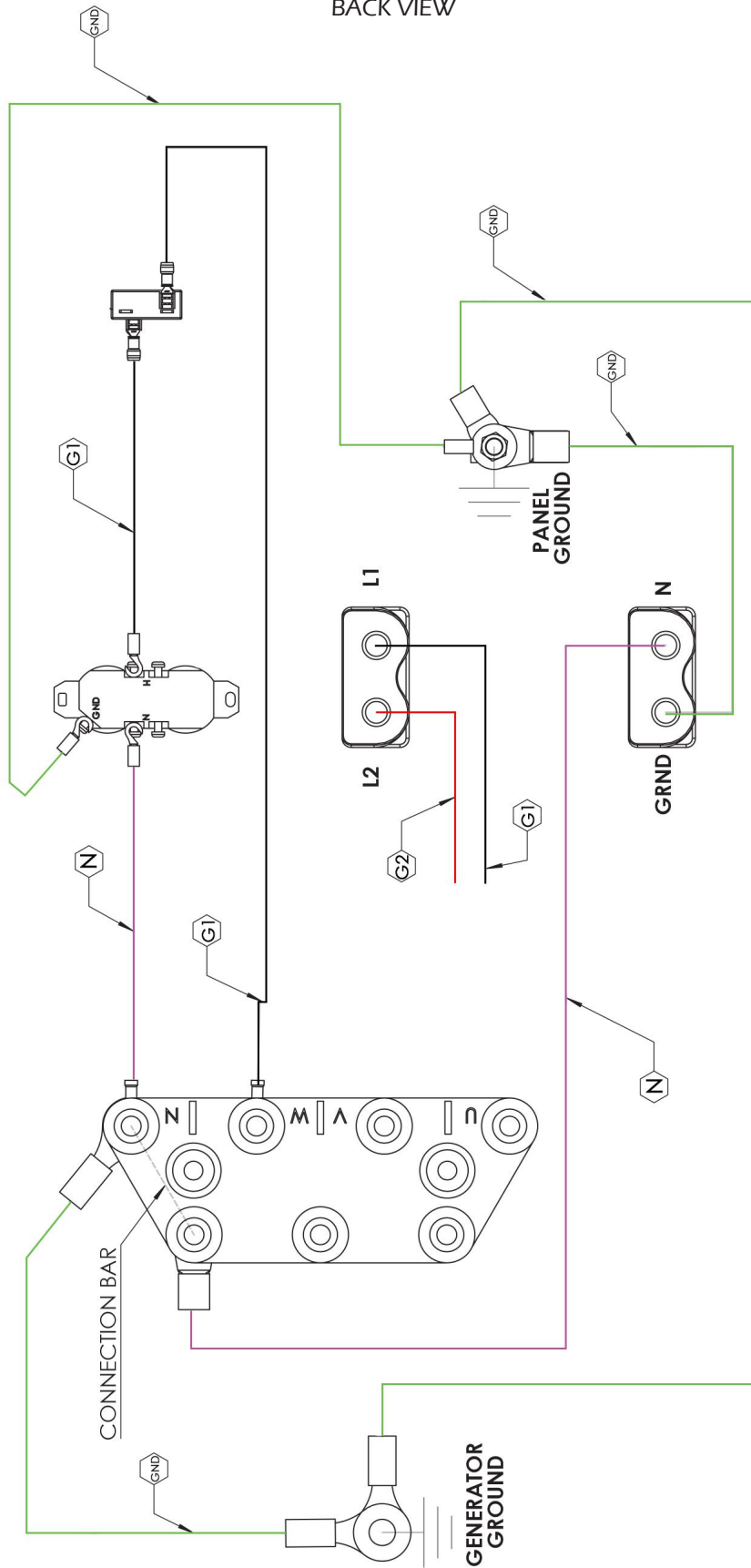

**70PTOT4-03**  
BACK VIEW

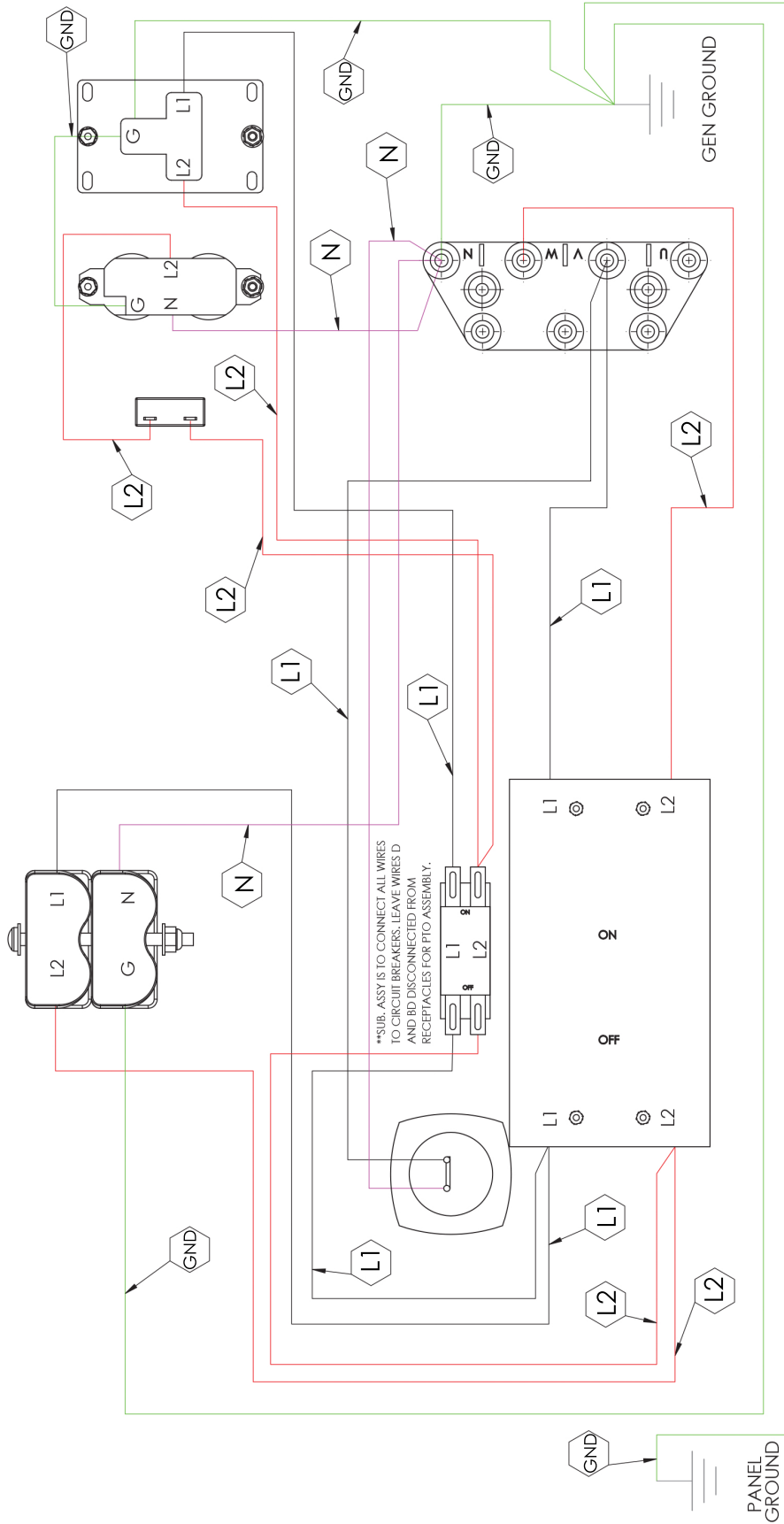

**70PTOT4-04 & 70PTOT4-17**  
BACK VIEW

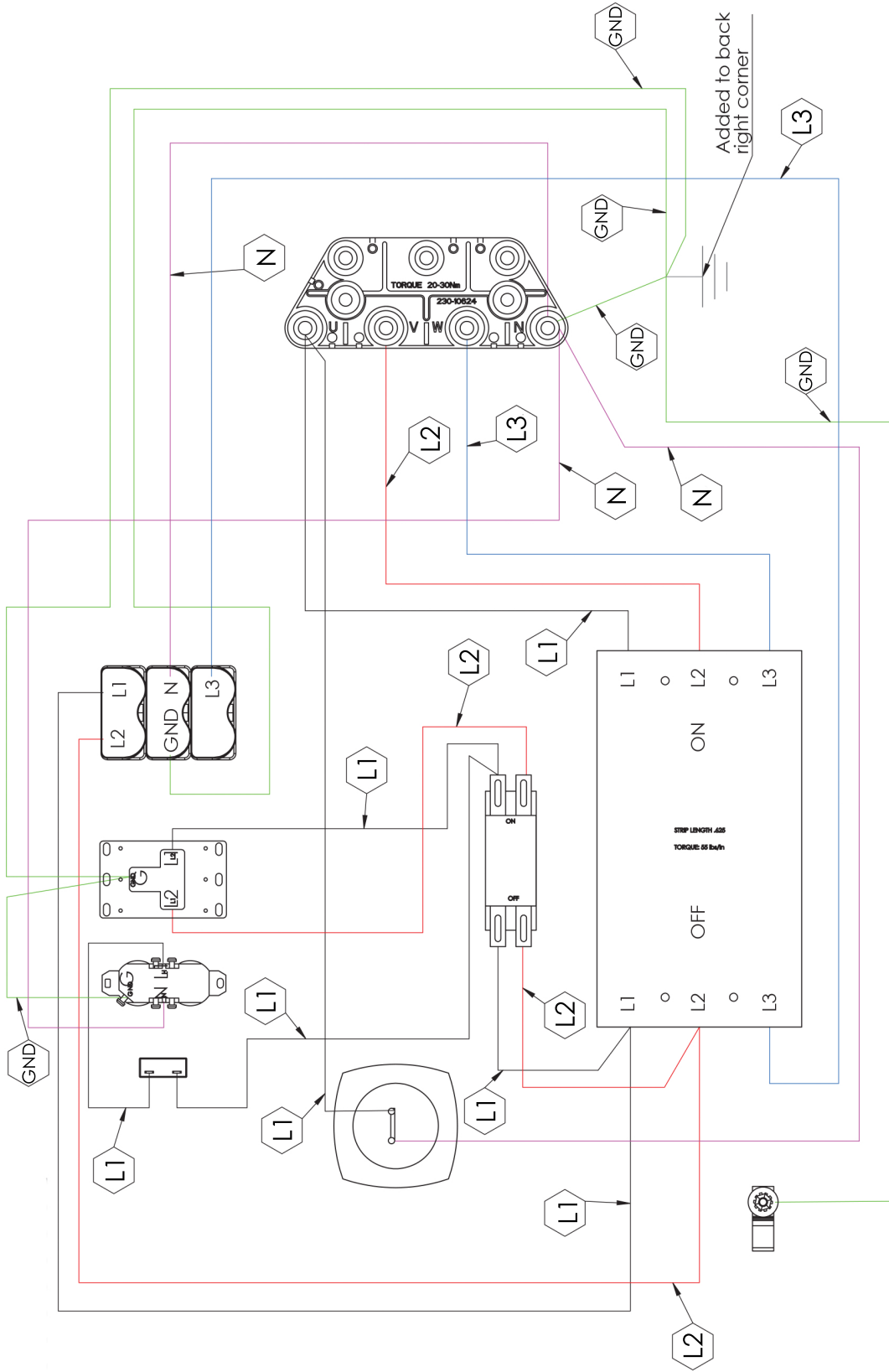



**80PTOT4-18**  
BACK VIEW

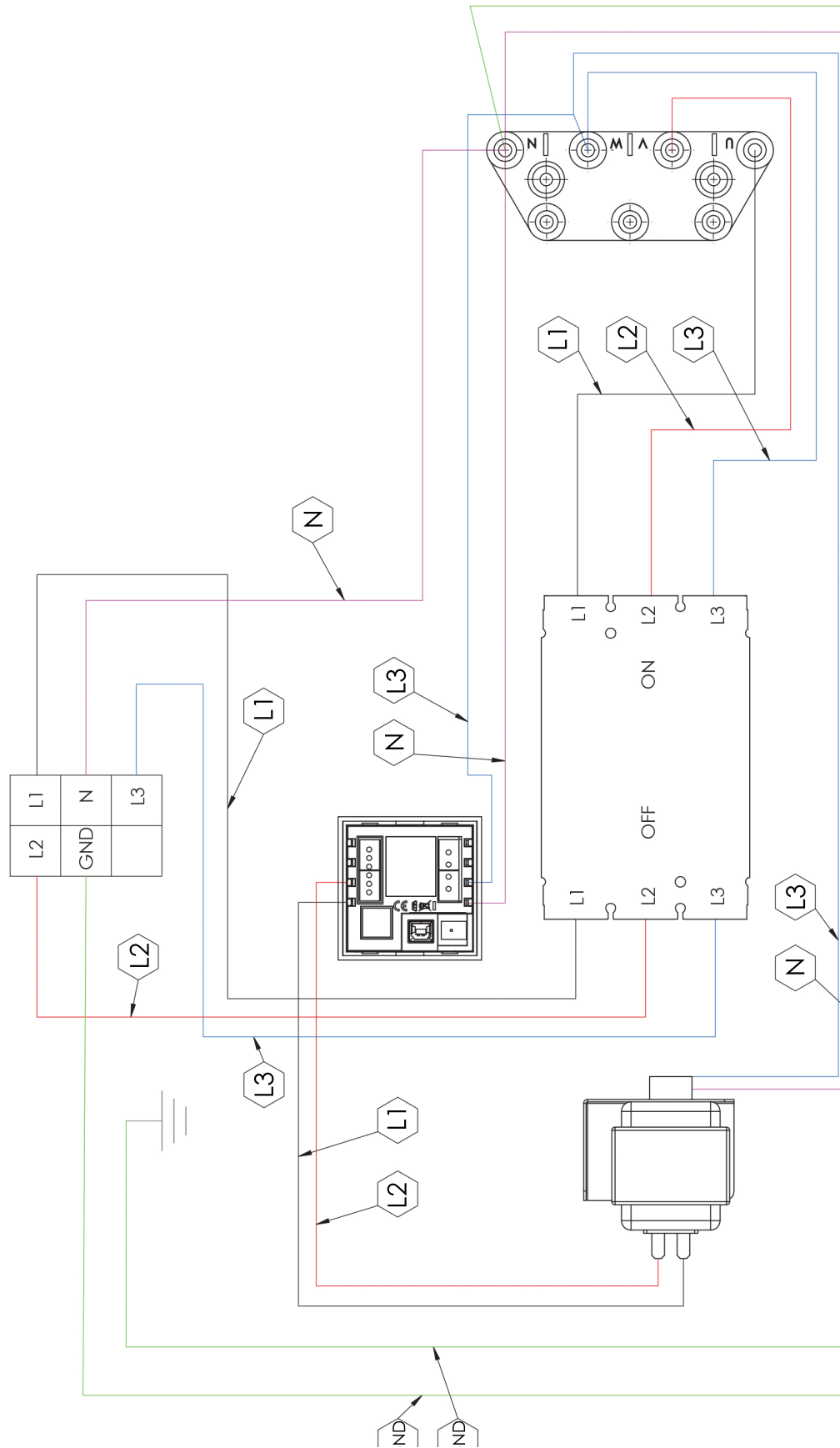

# WARRANTY STATEMENT

---

WINCO Incorporated warrants to the original purchaser for the warranty period that goods manufactured or supplied by it will be free from defects in workmanship and material, provided such goods are installed operated and maintained in accordance with WINCO written instructions.

WINCO's sole liability, and Purchaser's sole remedy for a failure under this warranty, shall be limited to the repair of the product. At WINCO's option, material found to be defective in material or workmanship under normal use and service will be repaired or replaced. For warranty service, contact a Winco Authorized Service Center within the warranty period from date of purchase.

\*NOTE: Units that are resold by original owner are not covered under this warranty. Any further warranty, whether expressed or implied, rests solely with the reseller.

## **THERE IS NO OTHER EXPRESS WARRANTY.**

To the extent permitted by law, any and all warranties, including those of merchantability and fitness for a particular purpose, are limited to the warranty period from date of purchase. In no event is WINCO liable for incidental or consequential damages.

Note: Some states do not allow limitation on the duration of implied warranty and some states do not allow the exclusion or limitation of incidental or consequential damages, so the above limitations may not apply in every instance. This warranty gives you specific legal rights which may vary from state to state.

## **WINCO, INC. WARRANTY EFFECTIVE DATE**

Air cooled units purchased for stock have 1 year to be sold. The warranty to the original retail customer commences on the date of sale of the product to them. All liquid cooled units have 180 days from the Winco invoice to submit a start up date. If no startup form is submitted, then warranty period starts on the Winco invoice date unit was sold.

Date of sale is defined as the day the customer takes delivery of the product. This warranty shall remain in effect to the original purchaser for the period stated on the sales literature. The warranty is not transferable and the retail customer must retain his original bill of sale as proof of purchase date.

WINCO, Inc. agrees to the following obligations during the warranty period:

1. To warrant any defect in material or workmanship of products sold under the WINCO and DYNA brand names in accordance with the warranty statements in the operator's manuals.
2. To reimburse authorized WINCO, Inc. Service Centers/Dealers for the cost of parts plus standard ground UPS shipping charges for all valid warranty repairs and to reimburse same said service centers/dealers for reasonable labor charges based on WINCO's current warranty labor reimbursement rate.
3. To furnish its authorized service centers/dealers with the necessary parts to make the repairs. WINCO Generator Warranty Periods & Restrictions

## **WINCO GENERATOR WARRANTY PERIODS & RESTRICTIONS**

### **Industrial Portables**

WL Models - 3 Years, See Notes 1 & 2

W Models - 3 Years, See Notes 1, 2, & 5

DP Models - 3 Years, See Notes 1 & 2

HPS Models - 2 Years, Home Use ONLY; Commercial use\* is 90 Day Warranty, See Note 1

### **EMERGEN-C (EC) Series**

2 Years, See Note 1

DE Series

1 Year/2000 hours, No Travel Time

Mobile Diesel Series

1 Year/2000 hours, No Travel Time

### **PTO Series**

15kW & 10kW - 1 Year, Limited Farm Standby Only

25kW thru 165kW - 3 Years, Limited Farm Standby Only/Commercial use\* 1 Year

### **Two Bearing Series**

1 Year, Bench Labor and Parts only

### **Gaseous/Packaged Standby Series (PSS)**

Air-Cooled Models (PSS8, PSS12, & PSS20) – 2 Years/2000 Hours Standby Only See Notes 3 & 4 Prime Power use 1 Year/2000 Hours See Notes 3 & 4

Liquid-Cooled Models (PSS21 - PSS150) - 2 Years/2000 Hours Standby Only See Notes 3 & 4 Prime Power use 1 Year/2000 Hours See Notes 3 & 4

### **Diesel Standby Series (DR)**

Liquid-Cooled Models (DR12 - DR600) - 2 Years/2000 Hours Standby Only See Notes 3 & 4

Prime Power use 1 Year/2000 Hours See Notes 3 & 4

Accessories (Installed on Generator or shipped loose)

1 Year from factory invoice or 2000 Hours (whichever occurs first)

## **Automatic Transfer Switches (ATS)**

See ATS Manufacturer's Warranty

### **NOTES**

Note 1: First 2 years of warranty coverage includes Parts and Bench Labor Only, no travel time or labor allowance for removal or reinstallation of the product from its application.

Note 2: 3rd Year warranty coverage is parts only/no labor.

Note 3: Round trip mileage is limited to 200 miles per trip and a total of 2 trips per repair unless authorized in writing by the WINCO Service Dept.

Note 4: Mileage allow on permanently installed units only. Trailer mount units is bench labor only.

Note 5: W3000 is a 1 Year Warranty.

\*Commercial use is defined as Construction, Rental, Prime Power, or use in a business of any type including agricultural and hobby. Prime Power use is defined as any application where the generator set is being used 'off-grid' where there is no utility power present. Standby use is defined as an application where utility power is present -and- the generator set is used as emergency backup during utility power outages.

WINCO reserves the right to change or improve its products without incurring any obligations to make such changes or improvements on products purchased previously.

### **EXCLUSIONS:**

WINCO does not warrant Engines. Engines are covered exclusively by the warranties of their respective manufacturers.

WINCO does not warrant Batteries, or Other Component Parts that are warranted by their respective manufacturers.

WINCO does not warrant modifications or alterations which were not made by WINCO, Inc.

WINCO does not warrant products which have been subjected to misuse and/or negligence or have been involved in an accident.

This warranty does not include travel time, mileage, or labor for removal or reinstallation of WINCO product from its application, unless specifically authorized.

### **WHAT IS COVERED BY WARRANTY**

1. Generator end including rotor, stator, end brackets, and bearing.
2. Control box including transformers, circuit breakers, wiring, resistors, and switches.
3. LP/NG fuel system including fuel solenoid, demand regulator, carburetor, and hoses.
4. Cradle assembly including cradle, cross member, and shock mounts that fail. Shock mounts damaged from rough handling are not covered.
5. Reasonable travel time for the PSS & DR series generators only, that are permanently installed.
6. Ground shipping charges for warranty parts, no premium service, domestic US shipments only.

### **WHAT IS NOT COVERED BY WARRANTY**

1. Products which have been subjected to alteration, modification, neglect or unauthorized repairs not approved in writing by Winco, Inc.
2. Products no longer owned by the original purchaser.
3. Products with shipping or freight damage. File a freight claim with the delivery carrier.
4. Products suffering normal wear, accidents, improper maintenance or improper protection in storage. Products damaged by rough handling, such as shock mounts on cradle assemblies.
5. Pressure or steam cleaning of products, cleaning of fuel system, or flushing of cooling system.
6. Replacement of filter, belts, antifreeze, or lubricants.
7. Electrical items, such as light bulbs, receptacles, spark plugs, or any items damaged by welding or jump starting.
8. Any repeat or shop come-back repairs resulting from poor service work or improper diagnosis and testing. Replacement of parts as a trial-and-error method of diagnosis will not be considered for warranty.
9. Replacement parts other than those sold by Winco, Inc.
10. Damage caused by fire, flood, lightning or any other natural disaster.
11. Damage caused by improper protection during installation, (i.e. not protecting contactor in the ATS panel and getting wire trimming or debris from drilling the box in the contactor coil or contacts.)
12. Damage caused by over loading of the generator and failure to adequately provide overload protection.
13. LP/NG fuel adjustments or conversion from one fuel to another.
14. Adjustment of any kind, all units are 100% load tested before shipping.
15. Any damage caused by the use of the equipment for purposes other than for which it was designed.
16. Engines - All engines used by Winco, Inc. are warranted by their respective manufacturer's.
17. Batteries - Must be returned to original battery manufacturer.
18. Damage caused by improper installation or failure to provide adequate ventilation.
19. Cosmetic repairs, such as repainting.
20. Freight charges for transportation to and from a Warranty Service Center.
21. Rental costs of renting replacement generators.
22. Travel time or service calls unless specifically authorized by Winco, Inc. in writing.

### **GENERAL INFORMATION**

The WINCO, Inc. Service Department is open from 7:30 AM to 4:30 PM Central Standard time.

It is located at 225 South Cordova Ave., Le Center, MN, 56057-1805. Phone Numbers: Service Department - 507-357-6831 FAX Line - 507-357-4857. Email address is service@wincogen.com The phone number to for the General Switchboard/Sales Department is 507-357-6821.

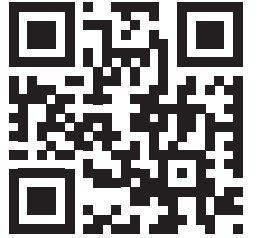

**WINCO**<sup>®</sup>  
**GENERATORS**



AN AMERICAN COMPANY

225 S. CORDOVA AVE • LE CENTER, MN 56057

Sales: 507-357-6821 • [sales@wincogen.com](mailto:sales@wincogen.com)

Service: 507-357-6831 • [service@wincogen.com](mailto:service@wincogen.com)

[www.wincogen.com](http://www.wincogen.com)

