

WINCO[®] GENERATORS

 An American Company

We produce our products in our 200,000 ft² facility located in Le Center, Minnesota, equipped with modern engineering, fabrication and assembly capabilities.



YOUR GEN



LED Display

Hours, RPMs, voltage, and frequency readings automatically cycle on the display.

Load Bars

Easily verify the load balance on each leg of the generator end.

Warnings

The LED will flash if any parameter gets outside of normal range. A warning will also be displayed when it is time for an oil change.

Receptacle Panel

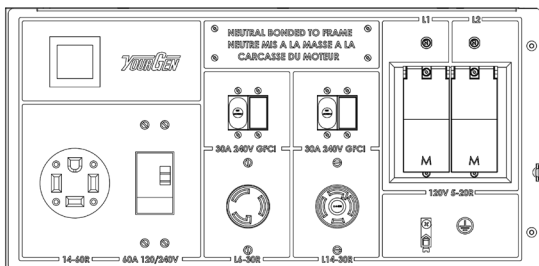

WL18000VE-03/B WL18000VE-03/C WL18000VE-03/D

16,500 WATTS

Rugged Steel Design.



B & S Commercial Vanguard Engine.

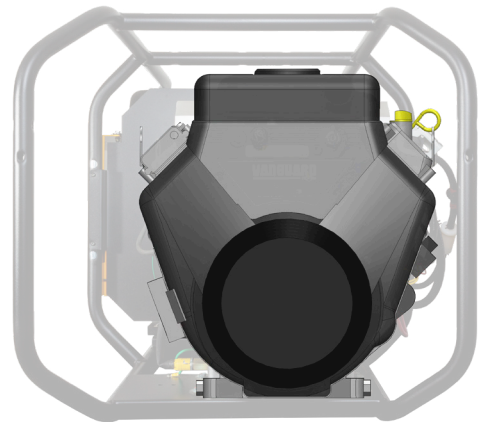

Brushless Industrial Genend.

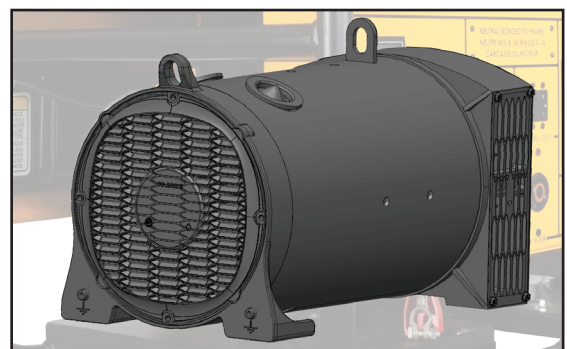

SPECIFICATIONS

ENGINE

| | |
|-------------------------------------|---------------------|
| ENGINE BRAND | BRIGGS & STRATTON |
| ENGINE MODEL | VANGUARD |
| ENGINE STARTER | ELECTRIC |
| ENGINE SPEED | 3600 RPM |
| ENGINE CYLINDERS | V-TWIN |
| DISPLACEMENT/TYPE | 895 CC / OHV |
| FREQUENCY REGULATION ⁽¹⁾ | +/- 3% |
| LOW OIL PROTECTION | STANDARD |
| RECOMMENDED OIL ⁽²⁾ | 5W-30 |
| OIL CAPACITY | 2.1 QT |
| FUEL TANK | 15 GAL |
| FUEL GAUGE | YES |
| FULL LOAD RUN TIME ⁽³⁾ | 6 HOURS |
| FUEL CONSUMPTION | GAL/HR |
| 100% | 2.49 |
| 75% | 2.01 |
| 50% | 1.56 |
| 25% | 1.25 |
| 0% | 1.00 |
| BATTERY SIZE ⁽⁴⁾ | BCI GROUP 26 500CCA |

NOTES: (1) Steady state frequency regulation. (2) The recommended oil is for normal applications. See operator's manual for the recommended oil for your needs. (3) Run time is estimated. (4) Battery not included.

SHIPPING

| | |
|---------------------------------|-------------------|
| SHIPPING DIMENSIONS (L x W x H) | 43.5" x 31" x 37" |
| SHIP WEIGHT | 504 LBS |
| FREIGHT CLASS | 70 |

OPTIONAL ACCESSORIES

| | |
|----------------------|----------------------|
| FOUR-WHEEL DOLLY KIT | WITH FLAT-FREE TIRES |
| COVER | 45" x 32" x 30" |
| BATTERY | BCI GROUP 26 500 CCA |
| MAINTENANCE KIT | 16200-011 |

ELECTRICAL

| | |
|--------------------------|---|
| STARTING WATTS | 18,000 |
| RUNNING WATTS | 16,500 |
| RUNNING AMPS @ 120 VAC | 137.5 |
| RUNNING AMPS @ 240 VAC | 68.75 |
| VOLTAGE REGULATION | CAPACITOR +/- 5% |
| MAIN CIRCUIT BREAKER | 60 AMP, 240V VAC |
| BONDED NEUTRAL | YES |
| 120 VOLT RECEPTACLES | (2) NEMA 5-20 20A DUPLEX (GFCI) |
| 120/240 VOLT RECEPTACLES | (1) 14-60R 60A (1) L14-30 30A (GFCI) |
| 240 VOLT RECEPTACLE | (1) NEMA L6-30 30A (GFCI) |
| YOURGEN METER | STANDARD |

GENSET

| | |
|------------------------------|-------------------------|
| MOTOR STARTING (CODE G) | 5 HP |
| DBA @ 7 METERS | 78 |
| TOTAL HARMONIC DISTORTION | < 6% |
| LIFTING EYE ⁽¹⁾ | STANDARD |
| 4-WHEEL DOLLY KIT | OPTIONAL |
| INSULATION | CLASS H |
| PROTECTIVE ROLL FRAME | 1.25" DIA. 14 GA. STEEL |
| ASSEMBLED IN | USA |
| EPA APPROVED | YES |
| CARB APPROVED | NO |
| TÜV CSA CERTIFICATION | NO |
| UNIT WARRANTY ⁽²⁾ | 3 YEARS COMMERCIAL |

NOTES: (1) Lifting eye shipped loose. (2) For more generator warranty, see operator's manual.

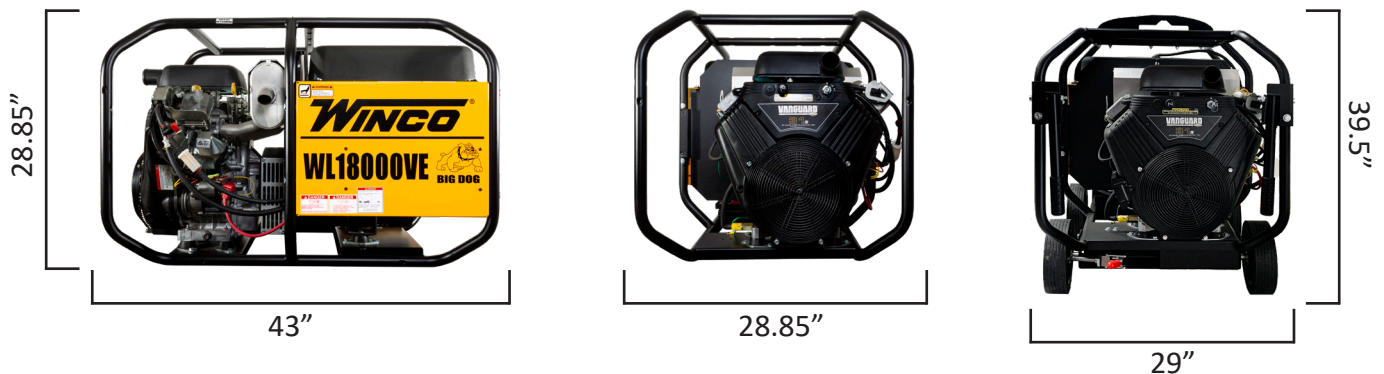

Specifications are subject to change without notice.

