

WINCO[®] GENERATORS

An American Company

We produce our products in our 200,000ft² facility located in Le Center, Minnesota, equipped with modern engineering, fabrication and assembly capabilities.



YOUR GEN



LED Display

Hours, RPMs, voltage, and frequency readings automatically cycle on the display.

Load Bars

Easily verify the load balance on each leg of the generator end.

Warnings

The LED will flash if any parameter gets outside of normal range. A warning will also be displayed when it is time for an oil change.

Receptacle Panel with GFCI protection

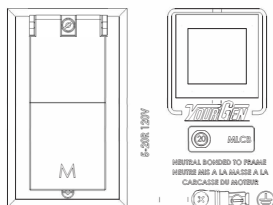

DP3000HR

2,500 RUNNING WATTS

Rugged Steel Design

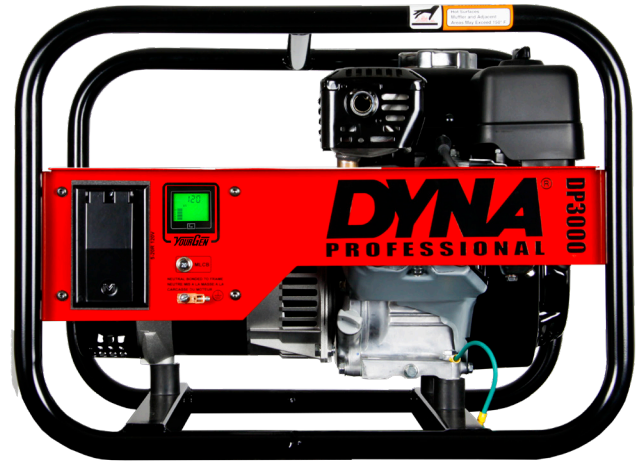

Honda GX160 Engine

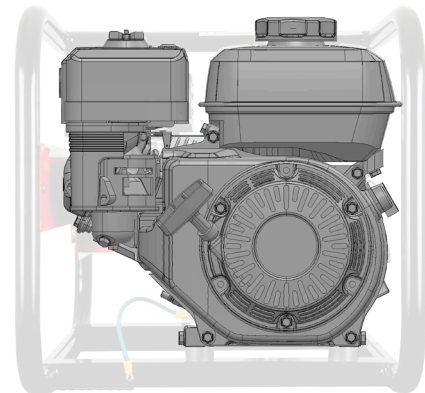

Brushless Industrial Genend. with clean power

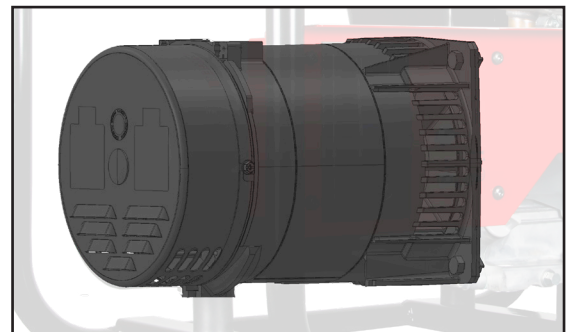

SPECIFICATIONS

ENGINE

ENGINE BRAND	HONDA
ENGINE MODEL	GX160
ENGINE STARTER	RECOIL
ENGINE SPEED	3600 RPM
ENGINE CYLINDERS	SINGLE
DISPLACEMENT/TYPE	160 CC / OHV
FREQUENCY REGULATION ⁽¹⁾	+/- 3%
LOW OIL PROTECTION	STANDARD
RECOMMENDED OIL ⁽²⁾	5W-30
OIL CAPACITY	0.6 QT
FUEL TANK	1 GAL
FUEL GAUGE	NOT AVAILABLE
FULL LOAD RUN TIME ⁽³⁾	2.2 HOURS
FUEL CONSUMPTION	GAL/HR
100%	0.45
75%	0.37
50%	0.29
25%	0.21

NOTES: (1) Steady state frequency regulation. (2) The recommended oil is for normal applications. See operator's manual for the recommended oil for your needs. (3) Run time is estimated.

SHIPPING

SHIPPING DIMENSIONS (L x W x H)	23.5" x 17" x 17"
SHIP WEIGHT	104 LBS
FREIGHT CLASS	70

ELECTRICAL

STARTING WATTS	3,000
RUNNING WATTS	2,500
RUNNING AMPS @ 120 VAC	20.8
VOLTAGE REGULATION	CAPACITOR +/- 5%
MAIN CIRCUIT BREAKER	20 AMP
BONDED NEUTRAL	YES
120 VOLT RECEPTACLES (GFCI)	(1) NEMA 5-20 20A DUPLEX
YOURGEN METER	STANDARD

DP3000HR

MOTOR STARTING (CODE G)	1 HP
DBA @ 7 METERS	74
TOTAL HARMONIC DISTORTION	< 1%
LIFTING EYE	NOT AVAILABLE
INSULATION	CLASS H
PROTECTIVE ROLL FRAME	1.25" DIA. 14 GA. STEEL

ASSEMBLED IN	USA
EPA APPROVED	YES
CARB APPROVED	NO
TÜV CERTIFICATION	CSA
UNIT WARRANTY ⁽¹⁾	3 YEARS

NOTES: (1) For more warranty information, see operator's manual.

OPTIONAL ACCESSORIES

GENERATOR COVER	29.5" x 22" x 22"
-----------------	-------------------

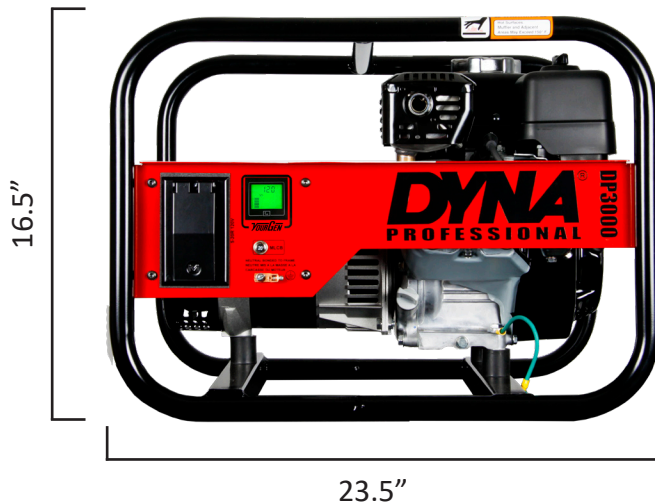

Specifications are subject to change without notice.

