



**DR400V4-XX/1
DR400V4-XX/2
GENERATORS**

INSTALLATION AND OPERATORS MANUAL

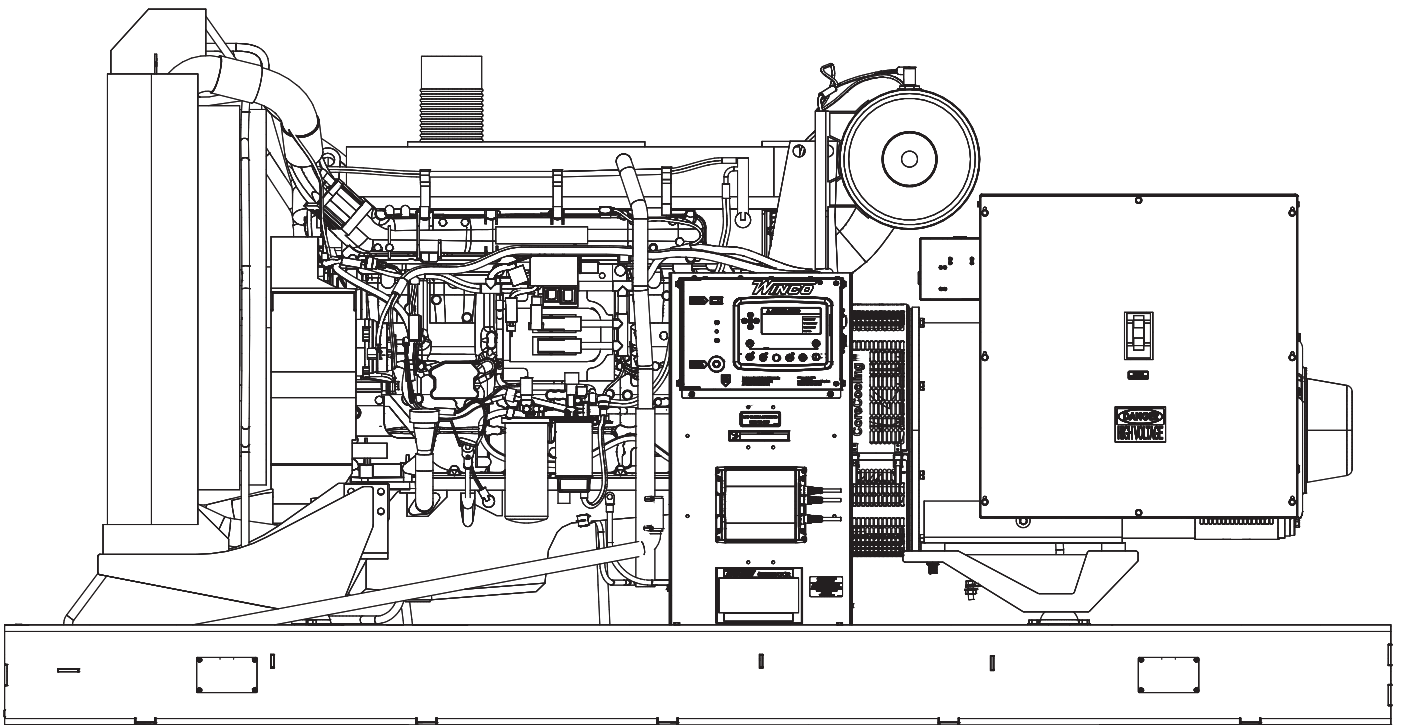

TABLE OF CONTENTS

SAVE THESE INSTRUCTIONS	3
SAFETY INFORMATION	4
SPECIFICATIONS	5
DR400V4	
INTRODUCTION	6
TESTING POLICY	
PRODUCT DESCRIPTION	
PREPARING THE UNIT	7
START-UP CHECK LIST	
UNPACKING	
LIFTING THE GENERATOR SET	
INSTALLATION	8
GENERAL INFORMATION	
ENGINE GENERATOR SET MOUNTING	
VENTILATION REQUIREMENTS	
EXHAUST INSTALLATION	
INSTALLING THE FUEL LINE	
LUBRICATION	
INSTALLING THE BATTERY	10
CONNECTING BATTERY CHARGER & BLOCK HEATER	
A.C. CONNECTIONS	12
D.C. CONNECTIONS	
DC INTERCONNECTIONS TO THE ATS	
TRANSFER SWITCH	
MOUNTING THE AUTOMATIC TRANSFER SWITCH	
STARTING PROCEDURE	15
INITIAL START UP	
MAINTENANCE	17
CHANGING THE OIL	
CHANGING OIL FILTER	
CHANGING COOLANT	
REFILLING COOLANT	
CHANGING AIR FILTER	
CLEANING RADIATOR	
DRAINING WATER IN FUEL FILTER	
CHANGING THE FUEL FILTERS	
STORAGE	
BRINGING OUT OF STORAGE	
MAINTENANCE SCHEDULE	19
TROUBLESHOOTING TABLE	20
AVR WIRING	21
WIRING SIZE TABLE	22
ENGINE SCHEMATIC	23
DSE 7310 MKII WIRING DIAGRAM	24
AC WIRING	25
WARRANTY STATEMENT	26

SAVE THESE INSTRUCTIONS

This manual contains important instructions that should be followed during installation and maintenance of the generator. Read and understand all instructions in the manual before starting and operating the generator.

USING THIS MANUAL

Congratulations on your choice of a WINCO generator. You have selected a high-quality, precision-engineered generator designed and tested to give you years of satisfactory service.

To get the best performance from your new generator, it is important that you carefully read and follow the operating instructions in this manual.

Should you experience a problem please follow the "Troubleshooting Tables" near the end of this manual. The warranty listed in the manual describes what you can expect from WINCO should you need service assistance in the future.

COPY YOUR MODEL AND SERIAL NUMBER HERE

No other WINCO generator has the same serial number as yours. If you should ever need to contact us on this unit, it will help us to respond to your needs faster.

MODEL _____

SERIAL NUMBER _____

PURCHASE DATE _____

DEALER NAME _____

DEALER PHONE # _____

SAFETY INFORMATION

This engine generator set has been designed and manufactured to allow safe, reliable performance. Poor maintenance, improper or careless use can result in potentially deadly hazards; from electrical shock, exhaust gas asphyxiation, or fire. Please read all safety instructions carefully before installation or use. Keep these instructions handy for future reference. Take special note and follow all warnings on the unit labels and in the manuals.

SAFETY DEFINITIONS

DANGER	Indicates an imminently hazardous situation which, if not avoided, will result in death or serious injury.
WARNING	Indicates a potentially hazardous situation which, if not avoided, could result in death or serious injury.
CAUTION	Indicates a potentially hazardous situation which, if not avoided, may result in minor or moderate injury. It may also be used to alert against unsafe practices.

CALIFORNIA PROPOSITION 65



WARNING: This product contains crude oil, gasoline, diesel fuel and other petroleum products, Antifreeze to which can expose you to chemicals including toluene and benzene, Ethylene glycol (ingested) which are known to the State of California to cause cancer, birth defects or other reproductive harm and developmental issues. For more information go to www.P65Warning.ca.gov.

DANGER: ELECTRICAL SHOCK

The output voltage present in this equipment can cause fatal electric shock. This equipment must be operated by a responsible person.

- A. Do not allow anyone to operate the generator without proper instruction.
- B. Guard against electric shock.
- C. Avoid contact with live terminals or receptacles.
- D. Use extreme care if operating this unit in rain or snow.
- E. Use only three-pronged grounded receptacles and extension cords.
- F. Be sure the unit is properly grounded for your application.

DANGER: DEADLY EXHAUST GAS

Exhaust fumes from any gasoline engine contain carbon monoxide, an invisible, odorless and deadly gas that must be mixed with fresh air.

- A. Operate only in well ventilated areas.
- B. Never operate indoors including attached garages
- C. Never operate the unit in such a way as to allow exhaust gases to seep back into closed rooms (i.e. through windows, walls, floors).

WARNING: FIRE HAZARD

Gasoline and other fuels present a hazard of possible explosion and/or fire.

- A. Do not refuel when the engine is running or hot.
- B. Keep fuel containers out of reach of children.
- C. Do not smoke or use open flame near the generator set or fuel tank.
- D. Keep a fire extinguisher nearby and know its proper use. Fire extinguishers rated ABC by NFPA are appropriate.
- E. Store fuel only in an approved container, and only in a well ventilated area.
- F. Follow local codes for closeness to combustible material.

CAUTION: PERSONAL INJURY

The muffler becomes very hot during operation and for a period after the unit has been turned off. Do not touch the muffler until it has completely cooled off.

CAUTION: NOISE HAZARD

Excessive noise is not only tiring, but continual exposure can lead to loss of hearing.

- A. Use hearing protection when working around this equipment for long periods of time.
- B. Keep your neighbors in mind when using this equipment.

CAUTION

Keep the generator and surrounding area clean.

- A. Remove all grease, ice, snow or materials that create slippery conditions around the unit.
- B. Remove any rags or other materials that could create a potential fire hazard.
- C. Carefully clean up any gas or oil spills before starting the unit.

CAUTION

All service, including the installation or replacement of service parts, should be performed only by a qualified technician.

- A. Use only factory approved repair parts.
- B. Do not work on this equipment when fatigued.
- C. Never remove the protective guards, covers, or receptacle panels while the engine is running.
- D. Use extreme caution when working on electrical components. High output voltage from this equipment can cause serious injury or death.
- E. Always avoid hot mufflers, exhaust manifolds, and engine parts. They can cause severe burns instantly.
- F. The use of the engine-generator set must comply with all national, state, and local codes.

SPECIFICATIONS

DR400V4

Generator

Wattage	400,000	400,000	400,000	400,000
Volts	120/208	120/240	277/480	346/600
Phase	Three	Three	Three	Three
PF	.80	.80	.80	.80
Amps	1,388	1,201	601	481
CB Size	2,000	1,200	600	600
Hertz	60	60	60	60

Engine

Model	Volvo TAD1353GE
Starting System	24 Volt
Muffler	Standard
Fuel Consumption (full load)	29.1 Gal/Hr

Engine Fluid Specifications

Fuel	ASTM D-975 -1D or 2D EN590 or equivalent
Oil Type	SEE LUBRICATION SECTION
Oil Capacity	50 Quarts
Cooling System	50/50 mix

Stamford Newage Model# S4L1D-G4
(Three phase 12 lead reconnectable generator)

Voltage Regulator	MX341
Rotor Resistance	1.44 ohms @ 22°C
Stator Resistance	0.0066 ohms per phase @ 22°C
Exciter Stator Resistance	18 ohms @ 22°C
Exciter Rotor Resistance	0.068 ohms per phase @ 22°C

INTRODUCTION

TESTING POLICY

Before any generator is shipped from the factory, it is fully checked for performance. The generator is loaded to its full capacity, and the voltage, current, and frequency are carefully checked.

Rated output of generator is based on engineering tests of typical units, and is subject to, and limited by, the temperature, altitude, fuel, and other conditions specified by the manufacturer of applicable engines.

PRODUCT DESCRIPTION

This engine-generator set is designed for unattended remote start operation. It can be operated as part of a fully automatic standby power system or independently as a local start unit in a prime power system. The engine-generator set is fully tested at the factory prior to shipment to insure proper operation of each individual component as well as the total system's performance and reliability.

The engine generator set consists of a multi-cylinder, liquid cooled engine nominally operating at 1800 rpm. The generator frequency regulation is maintained by the engine governor to within +/- 1.5 Hz (cps), from no load to rated load for standard mechanical governors and to within +/- .5 Hz or better for units equipped with an electronic governor. The generator is a single bearing, direct drive, rotating field design. The generator is connected to the engine flywheel via flexible drive disks. Generator set is skid mounted with isolation mounts between the engine and base on all units.

2 customer supplied 12 Volt batteries are required to complete the installation. Battery requirements are listed later under the battery installation section.

Unit Orientation Note: All references used in this manual for unit familiarization, access and component locations on the Generator Set are oriented from a TOP (plan) VIEW with engine at the FRONT and generator to the REAR.

WINCO uses a common junction box for all customer control and power connections (both AC output and DC control). The common electrical junction box is always on the left side at the generator end of the machine.

The engine is controlled and Generator Set operation is monitored for safe operation by a programmable microprocessor based electronic Engine Control Module (ECM) with an LCD digital display. The generator set ECM control is mounted on a vertical pedestal on the right side of the generator. The ECM is programmed with a cycle cranking sequence - 3 cycles of 15 seconds on/15 seconds off, and 5 minute cool-down delay. The cool-down delay can be changed in the field from 0 to 30 minutes by your installer. Other features, timing cycles, set points, and signal output capabilities are possible. Consult factory for procedure and passwords.

NOTICE

These units will automatically transfer if a power outage occurs while running in exercise mode.

GENERATOR SET

Every WINCO generator set has its own unique identity data plate. This data plate identifies the complete unit model number, the system serial number, and has links to the individual components that form the generator set in our factory records. Several of the major components also have their own individual data plates providing additional information to document build data for warranty and replacement parts.

ENGINE

Refer to the engine operators manual for more detailed operation and maintenance information.

CAUTION: EQUIPMENT DAMAGE

Be sure to check the engine oil level frequently as specified in the engine manual.

The engine manufacturer has established an excellent worldwide engine service organization; engine service is available from a nearby authorized dealer or distributor.

The rated power of each engine-generator is limited by the temperature, altitude, and all other ambient conditions specified by the engine manufacturer. Engine power may decrease 3½% for each 1000 feet above sea level, and will decrease an additional 1% for each 10 degrees Fahrenheit above 60° Fahrenheit. Units should not be operated in ambient temperature greater than 125° Fahrenheit.

GENERATOR

WINCO generator sets use brushless, AVR (Auto-Voltage Regulator) controlled broad-range generator ends. The generator converts rotational mechanical energy into electrical energy. These WINCO units are equipped with generators manufactured by Cummins Generator Technology. Each generator 'end' has its own data tag. A unique serial number is on the data plate.

MODEL NUMBER STRUCTURE

The WINCO alpha-numerical numbering consists of a base model designation, followed by an options section, separated by a dash mark. The base component of the model numbering system identifies an engine type, engine starting method, fuel type, kilowatt rating, engine manufacturer, and number of generator poles. Following the separation dash mark is the voltage connection.

Please note that some features or packages, such as NFPA level I & II, do not have an indication place in this numbering system. They are issued and built with an M-Spec (i.e. M-10372) number which can be found on the WINCO data tag. When the M-Spec is present, supplemental inserts will accompany this standard manual providing information about the special equipment and features installed. The standard model numbering key that can be used along with the data tag information and/or M-Spec supplements to determine the generator set's ratings and specifications.

PREPARING THE UNIT

START-UP CHECK LIST

A Start-Up Completion & Warranty Validation Form was sent along with this manual. This must be completed and returned to WINCO Inc. within 180 days of the factory invoice date.

If this form is not returned, the Warranty may be voided.

UNPACKING

1. As you receive your unit, it is critical to check it for any damage. If any damage is noted, it is always easiest to refuse the shipment and let WINCO take care of the freight claim. If you sign for the unit, the transfer of the ownership requires that you file the freight claim
2. Before proceeding with the preparations of your new generator for operation, take a couple of minutes to ensure the unit you have received is the correct model and review the specification pages in this manual to ensure that this unit meets your job requirements.

CAUTION: EQUIPMENT DAMAGE

These units are shipped with oil and a 50/50 mix of coolant. Be sure to check all fluid levels before operating. See engine manufacturer's instruction manual for recommended oil requirements before initial starting.

Once generator set is on-site:

1. Carefully remove the crate.
2. After inspecting the engine-generator for external, physical damage, locate and check the following items packed with the unit:
 - a. Installation and Operator's Manual.
 - b. Engine manufacturer's instruction manual.
 - c. Start-up and warranty validation form.
 - d. Battery hold-down brackets & hardware.
 - e. Unit components or accessory items shipped loose for on-site installation.
 - f. Optional accessories.
3. Remove main frame hold-down bolts.
4. Unit can now be lifted from shipping rails.

LIFTING THE GENERATOR SET

NOTICE: PERSONAL INJURY

To prevent injury to persons or equipment, observe the following guidelines when lifting the generator:

Due to the different designs, configurations, options, weights, site conditions, and available material handling equipment, specific lifting instructions are not provided for each individual generator set model. General guidelines provided are applicable to the entire generator line. It is the responsibility of the installing party to follow the lifting equipment's operator's manual to prevent injury to personnel and damage to the generator. Smaller generator sets may not require use of overhead lifting equipment and may be placed on the pad with basic material handling equipment, i.e. a forklift.

CAUTION

Do not attempt to lift the generator set by the means of the lifting eyes on the engine or generator end. These lifting points are only for the use during the manufacturing process and are designed for lifting of the individual generator set components.

WARNING

NEVER attempt to lift the fuel tank filled with fuel. Sloshing of the fuel can cause a shift in the balance of the fuel tank, making for a DANGEROUS, unbalanced lifting load. If the generator was shipped on the fuel tank, use the lifting points located on the fuel tank to move the entire generator set into place. DO NOT PLACE FUEL IN THE TANK PRIOR TO LIFTING.

INSTALLATION

This unit should be installed in a well ventilated area, ensuring the exhaust air cannot be recirculated back into the engine.

WARNING: PERSONAL INJURY

PERSONAL INJURY - Before proceeding with the installation, be sure the DSE7310 is in the "stop" position. Before proceeding with the installation, be sure the Generator MLCB (Main Line Circuit Breaker) is in the 'OFF' position and the unit starting battery is disconnected.

CAUTION:

This unit will get hot while it is running and for some time afterward.

GENERAL INFORMATION

This engine-generator set is generally supplied as weather enclosed packages for quick installation on an outdoor concrete pad. They are also available as open skid mounted units for indoor installation in a building or protective enclosure, properly ventilated, supplied by the installer. The factory weather enclosures are acoustical housing intended for outdoor installation only. Factory weather enclosed units are not intended to be used indoors and no support is available to assist in re-engineering finished packaged units.

All versions must be bolted to a solid base for proper operation. A properly designed concrete pad is necessary for stationary operation. A substantial DOT certified trailer is required for mobile applications. Consult a qualified, licensed electrician or contractor to install and wire the gen-set. The installation must comply with all national, state, and local codes.

Before beginning the installation process, recheck the voltage, phase, and amperage rating of the generator set. Be certain it can handle the intended load and are compatible with the intended loads. Plans for installation should be prepared with proper attention to mechanical and electrical engineering detail to assure a satisfactory system installation.

The information in this manual is offered only as a guide to finalizing your installation plans.

NOTICE

For full service switching of the entire load, the ATS must be 'SE' (Service Entrance) rated or must have a properly rated fusible disconnect installed before the ATS to protect the contacts.

ENGINE GENERATOR SET MOUNTING

This engine-generator set is generally supplied as weather enclosed packages for quick installation on an outdoor concrete pad. They are also available as open skid mounted units for indoor installation in a building or protective enclosure, properly ventilated, supplied by the installer.

The factory weather enclosures are acoustical housing intended for outdoor installation only. Factory weather enclosed units are not intended to be used indoors and no support is available to assist in re-engineering finished packaged units. The unit should be mounted to allow ample working room around it. A general rule to follow is to allow 24 inches or more of clearance for maintenance. Follow local codes for clearance from combustible surfaces.

The unit's main frame must be bolted securely to a solid base. The engine-generator is mounted on channels which are attached with special shock mounts to the main frame. This allows the engine-generator free movement without affecting the base or surrounding equipment.

WARNING: EQUIPMENT DAMAGE

Never mount these engine-generator sets to a wooden base/structure. Over time, the wood will deteriorate and the unit mountings will come loose. These units must be mounted to a steel or concrete base.

VENTILATION REQUIREMENTS

OPEN SKID

WARNING: EQUIPMENT DAMAGE

It is the installer's responsibility to ensure that there is sufficient cooling air available to prevent the engine and generator from over heating. Damage caused by overheating is not covered by warranty.

Providing proper air movement during your installation planning is essential. You will need to provide a fresh air inlet as well as a hot air outlet (to the outside of protection housing) for proper engine performance. These engine-generator sets are equipped with unit mount radiators and the engine is equipped with a pusher type fan. The hot air from the face of the radiator must be ducted out of the enclosure to ensure proper cooling. Failing to do so will allow the hot air to recirculate around the radiator causing the engine to overheat, resulting in an engine shutdown and damage. If louvers are used in front of the hot air duct to protect the unit from outside weather, the louvers should be 1 ½ times as large as the area of the radiator face to prevent back pressure.

Foam or other seals can be used to form a tight lip forcing all of the air from the engine fan out of the enclosure. In addition to a hot air discharge, you must plan a fresh air intake opposite the radiator discharge. Their fresh air inlets should be 1 ½ to 2 times larger than the radiator face. The extra air inlet area is required to minimize restriction and to provide combustion air for the engine. Do not block fresh air intakes with other equipment as this will result in insufficient air flow to the engine for cooling. Installing them opposite the hot air discharge will allow a sweeping flow of cooling air across the engine, preventing hot spots.

WARNING: EQUIPMENT DAMAGE

Failure to seal the radiator output will result in hot air recirculation that will result in equipment overheating and damage.

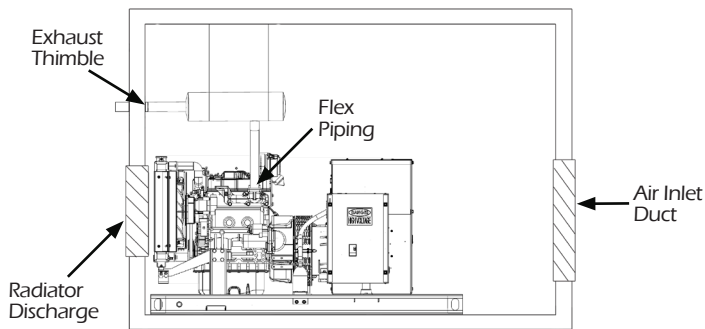

The WINCO installation manual OPM-112 contains additional information on indoor, open skid installations and is available electronically through our website or by requesting a copy from the factory. The unit should be mounted to allow ample working room around it. A general rule to follow is to allow 24 inches or more of clearance for maintenance. Follow local codes for clearance from combustible surfaces.

EXHAUST INSTALLATION

DANGER: PERSONAL INJURY

Improper exhaust installation will allow dangerous gases to seep into enclosed spaces causing a hazard to your health and/or death.

All exhaust must be piped out of the enclosure. When selecting a location to exhaust fumes make sure that the potential for contact with people is controlled. Exhaust can enter buildings through windows, ventilation systems and other openings if proper precautions are not followed.

The exhaust must be isolated from the vibration of the engine. If the exhaust is connected in a rigid system it will result in damage to the engine. The generator comes equipped with an engine mounted flex pipe to aid your installation. Ensure proper alignment with the generator. The flex can be eliminated if it is pushed to one side to make a connection.

The most direct path possible should be used to get to the outside of the enclosure. Each bend restricts the pipe and increases back pressure. It may be necessary to increase the exhaust pipe diameter in some applications.

The exhaust pipe is very hot. When passing through the structure it is critical that a thimble or other appropriate technique is used to dissipate the heat and prevent the structure from catching on fire.

INSTALLING THE FUEL LINE

WARNING: FIRE DANGER

Connecting rigid fuel line (i.e. steel or copper line) directly to the inlet fuel filter or fuel pump may cause the fuel line to crack during operation creating a serious fire hazard.

The fuel supply should be as close to the engine as possible. This will reduce the installation cost of fuel runs and minimize line losses. The diesel fuel supply should be no more than 3 feet below the fuel inlet on the pump. If

your fuel supply is lower than three feet you may have to install an additional lift pump to bring the fuel up to the mechanical fuel pump on the engine.

The information in this manual is offered to assist you in providing the proper fuel for your engine. However, this information is only provided to inform you of the engine's requirements and assist in making you aware of the decisions you must make. In no case should the instructions or information provided be interpreted to conflict with any local, state, or national codes. If in doubt, always consult your local fire marshal or fuel supplier.

Engine generator sets are properly adjusted before they leave the factory. Connecting a fuel supply with adequate supply volume is critical to reliable operation. Diesel units with optional base mounted fuel tanks are pre-plumbed to the mechanical fuel pump on the engine.

Open skid mounted Diesel units are often supplied with capped inlet and return lines. The use of a sustainable customer supplied flexible fuel line is essential between the engine and fuel supply to provide a vibration break between your fuel supply and the engine.

LUBRICATION

Before starting the engine, check the oil level in the crankcase. If it is low, refill to the full mark with the proper weight/grade of oil as recommended by the engine manufacturer's maintenance instructions. The necessity of using the correct oil, and keeping the crankcase full, cannot be over emphasized. Failure to use the proper oil and keep the crankcase properly filled will cause excessive engine wear and shorten its useful life.

Winco recommends our 5W-40 fully synthetic heavy duty engine oil to give you maximum cold weather protection while maintaining excellent performance in warmer weather. We have partnered with a national lubrication oil manufacturer to give you access to Winco private branded premium oil available at comparable prices to conventional oils. See your dealer for additional information.

INSTALLING THE BATTERY

CAUTION

In the following battery installation procedure, check to be sure the DSE 7310 MKII is in the "stop" position. This should be your last step before initial start-up.

These units require 4D batteries. The DR600 is 24 volt and requires 2 batteries. The batteries should be rated at a minimum of 1100 CCA. Installation of the highest CCA rated battery, within the correct BCI group, will increase cold weather starting performance. Gel batteries should not be used with the battery tender installed in the generator enclosure.

Installation and servicing of batteries must only be performed or supervised by personnel knowledgeable of batteries and the required precautions. Keep unauthorized personnel away from batteries.

When installing or replacing batteries, use the proper group/size starting battery. The battery should be a maintenance-free lead acid design. Deep cycle batteries will not work for this application.

CAUTION: PERSONAL DANGER

NEVER dispose a battery in a fire. The battery is capable of exploding.

DO NOT open or mutilate the battery. Released electrolyte is known to be harmful to the skin and eyes and to be very toxic.

These engine-generator sets are all NEGATIVE ground. Be very careful not to connect the battery in reverse polarity, as this may short circuit the battery charging system on the engine.

CAUTION

A battery presents a risk of electrical shock and high short circuit current. The following precautions must be observed when working with batteries:

1. Remove watches, rings, and other metal objects.
2. Use tools with insulated handles.
3. Check both the battery cable ends and the battery posts to be sure they are free of corrosion.
4. Always connect the battery positive cable first and then connect the battery negative cable. When removing the battery cables from the battery, reverse the procedure, disconnect the negative first and then the positive cable.
5. Be sure all connections are tight and coat the terminals and cable ends with dielectric grease.

WARNING

The electrolyte is diluted sulfuric acid that is harmful to the skin and eyes. It is electrically conductive and corrosive. The following precautions must always be taken.

1. Always wear full eye protection and protective clothing.
2. Where electrolyte contacts skin, wash off immediately with water.
3. If electrolyte contacts the eyes, flush thoroughly and immediately with water and seek immediate medical attention.
4. Spilled electrolyte is to be washed down with an acid neutralizing agent. A common practice is to use a solution of one pound of bicarbonate of soda (baking soda) to one gallon of water. The bicarbonate of soda solution is to be added until the evidence of reaction (foaming) has ceased. The resulting liquid is to be flushed with water and the area dried.

DANGER: EXPLOSIVE FIRE RISK

1. Never smoke when near batteries.
2. Do not cause a flame or spark in the battery area.
3. Always discharge static electricity from your body before touching batteries by first touching a ground metal surface.

SERVICING BATTERIES

Batteries used on these units may, over time, lose water. This is especially true if you are using a trickle charger to maintain your battery. Different types of batteries require various types of maintenance. Refer to the battery manufacturer for specific recommendations.

NOTE: Always make sure that a new battery is fully charged before installing it on a generator set. Failure to do so can cause damage to the engine control module in the generator set.

All connections must be clean and tight. Depending on your battery type, check the electrolyte in the battery periodically to be sure it is above the plates. Never allow the battery to remain in a discharged condition.

CONNECTING BATTERY CHARGER & BLOCK HEATER

A three-stage battery charger is provided standard on this unit. The charger is an Automatic Battery Charger & Maintainer. This charger has three rates of charging. During the first mode, known as Bulk charging, the charging current is limited to 10 Amps at a voltage of up to 14/27 Volts. The yellow LED will be on constantly during this stage. When the charging rate drops to 2.5 Amps, the charge will enter the ABSORPTION charging mode. During this mode, the yellow LED will be flashing. The charging voltage is held at 14/27 Volts and the charging rate gradually reduces the amount of current (Amps) flowing to the battery to 100% charged state. The battery can be left on this mode indefinitely. During this mode, the green LED

will be on constantly.

This charger is mounted under the customer connection on the control side of the generator and plugged into the receptacle mounted in the AC connection cabinet. The battery charger receptacle is to be powered by a GFCI circuit and installed in accordance with the United States National Electric Code. It is suggested that this circuit be fused for 15 amps. The block heaters on these units are 3000 watt heater will need to be hard wired in.

The engine block heater installed on this unit should also be hard wired in. The block heater is thermostatically controlled and when plugged in will maintain the engine coolant temperature between 100 and 120 degrees F.

A.C. CONNECTIONS

NOTICE: CLASS 1 WIRING METHODS ARE TO BE USED FOR ALL FIELD WIRING CONNECTIONS TO TERMINALS OF A CLASS 2 CIRCUIT

All wiring must be completed in accordance with the National Electric Code as well as any state and local codes.

You must pay particular attention to wire size requirement for the amperage of service you are dealing with. The table below provides you guidance on wire sizing based on both wire type and amperage. **Wire amperages have been derated for 40° C ambient temperatures operation.**

WARNING

Make sure the generator is disconnected from the battery to prevent accidental starting.

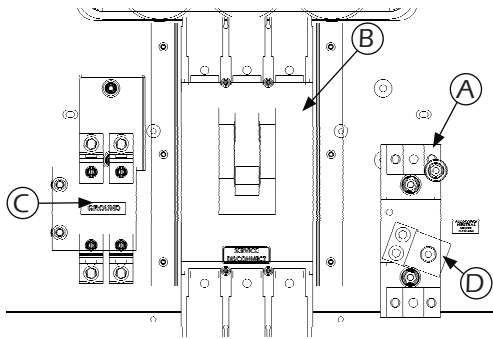

A. NEUTRAL LUGS:

These lugs are isolated from ground and provided for you to connect your neutral wire from the transfer switch to the generator.

B. GENERATOR CIRCUIT BREAKER:

WARNING: PERSONAL INJURY/DEATH

A mainline circuit breaker has been provided inside the generator housing. During all wiring installations, make sure the breaker is in the OFF position and the generator operating switch is in the OFF position.

Your generator is equipped with an electronic circuit breaker. These premium circuit breakers are adjustable allowing you to fine tune them for your applications. WINCO uses an adjustable breaker, which allows us to use the same breakers in reconnectable units. These adjustment should only be made by a competent technician to prevent equipment damage, injury or death. The following features are adjustable:

Long-Time Protection:

The dial that controls the long-time protection is labeled I_T . The dial correlates with the amperage setting of the long-trip. All the wires should be sized equal to or greater than this dial position. The breaker will not trip at 105% of the dial position current and will trip within two hours of 120% of the dial position.

Short Time Protection:

The dial that controls the short-time protection is labeled I_{sd} ($\times I_n$). This setting controls the inrush current the

circuit breaker will allow. The number on the dial is the current allowable based upon the long-time (I_T) setting of the breakers. For example, if the I_T of the breaker is set at 200 and the I_{sd} is set at 1.5 the short term breaker setting is 250 amps.

Instantaneous Protection:

The dial that controls the instantaneous protection is labeled I_i ($\times I_n$). The breaker will trip immediately upon reaching this current level. The dial is set as a multiple of the Long-time (I_T) setting.

The circuit breaker has three LED lights on it.

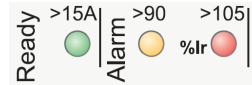

Ready LED (green)

Blinks slowly when the electronic trip unit is ready to provide protection.

Overload Pre-Alarm LED (orange)

Shows a steady light when the load exceeds 90% of the I_T setting.

Overload Alarm LED (red)

Shows a steady light when the load exceeds 105% of the I_T setting.

C. GROUND LUG:

These ground lugs are bonded to ground and are provided for you to connect your ground wire from the transfer switch to. The lugs will accommodate #6 AWG to 300 MCM and should be torqued to 21 ft. lbs.

D: NEUTRAL TO GROUND LEAD LUG:

This lug is provided on the neutral terminal block to allow you to run a neutral to ground lead if you are using the generator in a stand alone application. This would be an application where there is not a distribution panel and no other ground to neutral bond in the wiring system. If a grounding wire is attached here, remove the floating neutral label in the panel. This will not be used when you are wiring a generator and transfer switch into an existing power system.

WARNING: EQUIPMENT DAMAGE

When installing a three-phase 240 Volt system, be sure you know which lead is the high voltage "wild" leg (208 Volt line to neutral). The generator normally carries the high voltage on the G2 lead.

All wires should be installed in rigid or flexible conduit (knockouts are provided in the control box).

D.C. CONNECTIONS

CAUTION
Never run the AC and DC wiring on the same conduit.

All DC connections are completed on the terminal strip just below the engine control. All DC connection must be separate conduit. You cannot mix AC and DC leads at the same conduit.

To install the wires, reference the following picture. Use a small flat head screwdriver to push the release spring inside the square hole (A). While the release is being pushed, insert the wire into the larger circular hole (B). Remove the screwdriver to secure the wire into place.



CONNECTION BOX TERMINALS

Wire size requirements for each of the connections may vary but terminal lugs should be used for all connections. Torque spec for terminal lugs is 9 in. lbs.

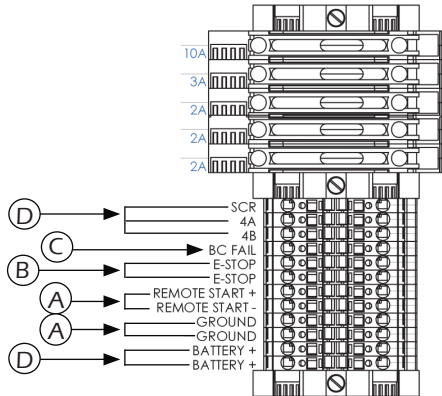

A. CUSTOMER REMOTE START CONNECTION TERMINALS.

The two remote start leads from the Automatic Transfer Switch are connected to the two terminals marked GROUND & START. The WIRE in terminal GROUND is battery negative and the wire in the terminal labeled START is your remote start lead. Closing these two leads together will signal the DSE 7310 MKII to go into an autostart mode and start up the generator.

Depending on the distance, 14 to 16 gauge standard wire should be used. It is suggested that these wires be labeled S1 (ground) and S2 (start). The terminal blocks are designed to use terminal lugs on all wires and the screws should be torqued to 9.6 in. lbs.

Note: Any relay closure can be used to start and stop this generator. As long as the contact stays closed, the generator set will continue to run. Once the relay is opened, the unit will shut down and remain on standby mode until the remote start relay is closed again.

B. ESTOP - & ESTOP +.

These two terminals are shipped with a jumper installed. If your application requires the installation of a Remote Emergency Stop switch, remove the jumper and wire your switch to these terminals. This unit will not start and run without the jumper installed or a remote N/C switch installed.

C. BATTERY CHARGER FAILURE.

Battery charger failure relay input from remote battery charger to DSE 7310 MKII controller.

D. REMOTE DISPLAY PANEL INTERFACE TERMINALS.

These interface terminals are pre-wired to allow for the connection of a remote display. This display allows for the remote annunciation of alarms at a location such as a nurse's station or a control room. This display can be used to meet the remote annunciation requirements of the NFPA 110 standards (this feature meets the annunciation requirements in applications requiring NFPA 110 level on protection).

DC INTERCONNECTIONS TO THE ATS

Two control wires are required between the ATS panel and the generator control terminal box. Depending on the distance, 14 and 16 gauge stranded wire should be used. These wires should be labeled S1 and S23.

WARNING
Be sure Engine/Generator is in the OFF position before you make any DC interconnections.

TRANSFER SWITCH

ASCO 300 UL SWITCH

When Normal Source Fails	Terminals On Transfer Switch
Contact Closes	TB1 and TB2
Contact Opens	TB1 and TB3

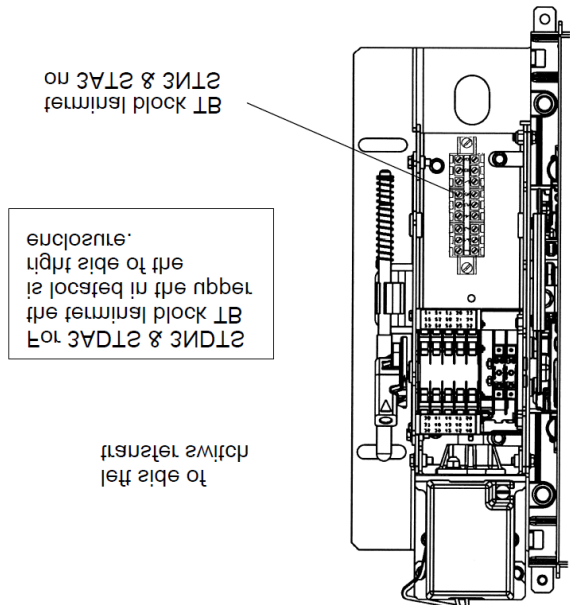

Engine start and auxiliary circuit terminal block TB located on 3ATS & 3NTS transfer switch.

MOUNTING THE AUTOMATIC TRANSFER SWITCH

WARNING: FIRE HAZARD

All wiring must be done by a licensed electrician, and must conform to the National Electrical Code and comply with all the local codes and regulations. Check with the local authorities before proceeding.

INSTALLATION NOTES:

Because of many different types of service, feeder and distribution equipment, no specific wiring instructions can be provided. It is recommended that only copper wire be used. In all cases it is essential that while the load is connected to the generator, there can be absolutely no feedback from the generator to the power line or the power line to the generator. When properly installed, the normal ATS Control and safety system will eliminate all paths and feedback.

To wire the automatic transfer switch into existing wiring, first determine which circuits will be on the emergency load circuit. If the entire load is transferred, the transfer switch can be wired directly after the watt-hour meter and the service entrance, providing the service entrance ampere rating is within the transfer switch's rated capability.





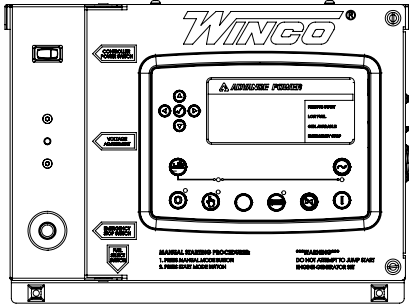

If only specific circuits are to be powered under emergency power failure conditions, an additional distribution panel designated "emergency distribution panel" must be installed.

All selected emergency circuits are removed from main distribution panels and installed in the emergency distribution panel. The ATS is then installed between the main panel and the emergency distribution panel. Suggested circuits: freezer, refrigerator, furnace, emergency lights, sump pump, emergency outlet circuits, etc. Total running load must not exceed generator rating.

STARTING PROCEDURE

CONTROL LAYOUT



	<p>STOP/RESET - This button places the module into its Stop/Reset mode. This will clear any alarm conditions for which the triggering criteria have been removed. The fuel supply de-energizes and the engine comes to a standstill. Should a remote start signal be present while operating in this mode, a remote start WILL NOT occur.</p>
	<p>MANUAL MODE - This button places the module into its Manual Mode. Once in Manual Mode, the model responds to the Start button to start the generator and run it off load.</p>
	<p>START - Pressing this button from STOP/RESET will start the engine and run the load.</p>
	<p>AUTO MODE - This button places the module into its Auto Mode. This mode allows the module to control the function of the generator automatically.</p>
	<p>ALARM/LAMP TEST - This button silences the audible alarm in the controller, de-activates the Audible Alarm output (if configured) and illuminates all of the LEDs on the module's face as a lamp test function.</p>
	<p>MENU NAVIGATION - Used for navigating the instrumentation, event log, and configuration screens.</p>
	<p>A small rocker switch is located on the underside of the engine control cabinet.</p> <p>On gaseous models, the engine timing is controlled by the ECU on the engine and you need to tell it what fuel you want to operate on; LP or NG.</p> <p>On diesel models, this switch has been disconnected and will do nothing.</p>

PROTECTIONS

When an alarm is present, the common alarm LED if configured will illuminate. The LCD display will show an icon to indicate the failure.

WARNINGS

Warnings are non-critical alarm conditions and do not affect the operation of the generator system, they serve to draw the operator's attention to an undesirable condition.

Warning alarms are self-resetting when the fault condition is removed. The icon will appear steady in the display.

SHUTDOWN

Shutdowns are critical alarm conditions that stop the engine and draw the operator's attention to an undesirable condition. Shutdown alarms are latching. The fault must be removed and the STOP/RESET button pressed to reset the module. The icon will be flashing in the display.

INITIAL START UP

WARNING: EQUIPMENT DAMAGE

Before attempting to start this unit, complete your pre-start checklist and ensure the generator mainline circuit breaker is in the proper position prior to starting. Starting this unit without it properly connected can cause serious personal injury or equipment damage.

DO NOT jump start these engine-generator sets. Starting these units on a low battery or jump starting them will cause damage to the engine control module.

Use the following check list to verify correct installation before starting the engine.

- Engine oil. Fill as required with proper grade/qty.
- Engine coolant. Fill as required with proper mixture.
- Unit mounting base properly bolted down.
- Clearance for service and maintenance on all sides.
- Proper fuel line material and size.
- All fuel line connections tight.
- Battery connections clean and tight
- Battery fully charged.
- All AC and DC wiring installed and properly protected.
- Compressor oil. Fill as required with proper grade/qty.

After completing the previous checklist, the engine-generator set is ready for initial start-up.

MANUAL MODE

1. Press and release the Manual Mode button. The small LED light next to it should come on.

Note: There is no start delay in this mode of operation.

2. Press and release the green Start Engine button. The DSE 7310 MKII will send two signals to the engine. The first signal wire #21 will engage the fuel solenoid, the second wire, #22, will engage the starter on the engine. At this point the DSE7310 will start the cranking cycle (10 seconds on and 10 seconds off).

Note: Wire #93 is energized to turn on the glow plugs for 15 seconds first and then the starter and fuel solenoid are engaged.

If the engine fails to start during this cranking period, the starter motor is disengaged and goes into a rest mode after which a second attempt is made to start the engine. Should this sequence continue through 3 cranking cycles the start sequence will be stopped and the display will show 'FAILED TO START'.

3. During manual operation, the load will not normally be applied to the generator. But caution must be used, if the line power should fail or be turned off the transfer switch during manual operation the load may be applied to the generator.

With the engine running smoothly check the no load voltage and frequency on the digital display. The voltage should be 208/240/480 AC depending on which model you have and a frequency of 59.5 to 60.5 hertz (Hz).

If you have the proper voltage at the generator the next step is to check the voltage at the generator terminals in the Automatic Transfer Switch. The voltage between the G1 and the G3 terminals should be the same as it was on the generator front panel. The voltage should also be checked between the hot terminals (G1 and G3) and the G-N to be certain of a balanced voltage output and a solid neutral connection. The voltage between G1 and G-N should be about 120 volts AC (277 on 480 units). The same approximate voltage should be found between terminals G3 and G-N (120 volts AC).

On three phase panels the G2 voltage level should also be checked. ON 240 VOLT (DELTA) SYSTEMS BE SURE YOU KNOW WHERE THE HIGH VOLTAGE "WILD" LEG IS. IT MUST BE IN THE SAME LOCATION ON THE LINE SIDE AS IT IS ON THE GENERATOR SIDE.

(i.e. if it's on L-3 on the line side it must be on G-3 on the generator side. Also on three phase systems make sure that the rotation is the same on the generator as it is on your line power. Failure to insure proper rotation will cause three phase motors to spin backwards possibly damaging them.

NOTICE

If for any reason during the check out procedure the voltage and frequency are not correct, depress the STOP/RESET button and correct the trouble before proceeding.

4. Stopping - There are two ways to stop the unit when it is in the manual mode. Pressing the STOP/RESET button will stop the unit immediately. Pressing the AUTO mode button will stop the unit but only after the cool down timers have timed out and there is no remote start signal being sent to the unit.

AUTO MODE

To activate the automatic start mode you will just need to depress the AUTO button, the LED indicator beside the button confirms that the unit is in automatic mode.

To test the Automatic Transfer Switch, follow the instruction on the operator's manual that came with the transfer switch. If you get a fault during the initial start up or prior to start up, it is most likely a false warning light. Simply reset the ATS start over.

Once you have completed testing of the ATS, be sure you ALWAYS leave the system in the standby mode, unless servicing the unit. For standby operation, press the AUTO button on the front of the control. The green light should light up next to the AUTO button.

NOTE: For setting the exerciser circuit, for all ATS, see the operator's manual shipped with the ATS.

MAINTENANCE

CHANGING THE OIL

CAUTION: PERSONAL INJURY

Only change oil when the engine is not running and is at a low temperature in order to avoid the risk of burns.

WINCO recommends our 5W-40 fully synthetic heavy duty engine oil to give you maximum cold weather protection while maintaining excellent performance in warmer weather. We have partnered with a national lubrication oil manufacturer to give you access to Winco private branded premium oil available at comparable prices to conventional oils. See your dealer for additional information.

WINCO has plumbed an oil drain valve to the outside of the unit. Attach a customer supplied 5/8" hose to conveniently run the oil to a drip pan or suitable container for catching the oil.



Oil changes must be done when the engine is hot.

1. Connect the drain hose to the oil drain pump and check that no leakage can occur.
2. Pump the oil out (or remove the bottom drain plug and drain the oil).
3. Remove the drain hose (or install the bottom drain plug).
4. Fill with engine oil.

CHANGING OIL FILTER

The filter must be replaced when the lubricant oil is changed.

Only use filters with a filtering degree equal to the original filter.

CAUTION: PERSONAL INJURY

Only change oil when the engine is not running and is at a low temperature in order to avoid the risk of burns.

1. Remove all oil filters with a suitable oil filter extractor.
2. Clean the mating surface of the oil filter bracket. Make sure that no pieces of old oil seal are left behind. Carefully clean round the inside of the protective rim on the oil filter bracket.
3. Put a thin layer of engine oil on the seal rings of the new fuel filters.

4. Install the new oil filters. Tighten the filters $\frac{3}{4}$ -1 turn after they touch.
5. Top up with engine oil, start the engine and let it run for 20-30 seconds.
6. Turn off the engine, check the oil level and top up as required.
7. Check sealing round the oil filters.

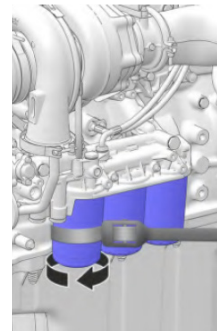

CHANGING COOLANT

Usage Region	Outside Temperature	Long-Life Coolant Concentration
Warm region	10°F or above	40%
Cold Region	-22°F - 10°F	60%

CAUTION: PERSONAL INJURY

Only proceed when the engine is not running and is at a low temperature in order to avoid the risk of burns.

1. Open the pressure caps on the expansion tank and the filler cap to the radiator (A).

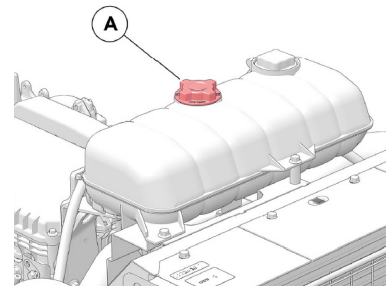

2. Open all drain points. Drain the coolant from the radiator and engine block, using the drain hose. The drain nipples are situated under the radiator on the right side of the engine block.
3. Check that all coolant drains out. Deposits may be found inside the drain plug/tap, and need to be cleared away. There is otherwise a risk that the coolant could remain and cause frost damage. Check whether the installation has any further taps or plugs at the lowest points of the cooling water pipes.
4. Close any taps and check that the spring-loaded covers on the nipples close completely. Install the rubber plugs and the filler cap(s).

REFILLING COOLANT

1. Check that all drain points are closed.
2. Open the caps to both the expansion tank and the radiator. Fill the expansion tank so that the coolant reaches the MAX mark on the sight glass. Close the filler caps.

- Bleed the system at the bleeding nipple.
- Start the engine when the coolant system is completely filled and vented. Open any bleeding nipples a short while after starting, to allow trapped air to escape.
- Start the engine after approx. one hour and check the coolant level. Top up with coolant as required.

CHANGING AIR FILTER

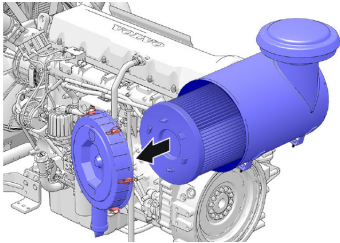

Do NOT remove filter while engine is running.

- Unclasp the air filter cover. Remove the filter by pulling/rocking it straight out.
- Wipe clean around attachment point.
- Replace the filter. Replace the cover, securing the fasteners.

CLEANING RADIATOR

The surfaces of the radiator come into contact with the outside air and can be subject to deposits and impurities. Clean in accordance to the maintenance schedule with compressed air or steam.

DRAINING WATER IN FUEL FILTER

WARNING: EQUIPMENT DAMAGE

Clean the exhaust valve prior to checking the pre-filter to reduce the risk for system contamination.

Do NOT perform while the engine is running.

- Place a container for collecting liquids under the pre-filter.
- Unscrew the plug located at the bottom of the filter.
- Drain the fluid until only fuel comes out.
- Fully hand-tighten the plug.
- Dispose of liquid in accordance to local codes. DO NOT dispose or allow liquid to seep into the ground or sewer systems, doing so will cause environmental damage.

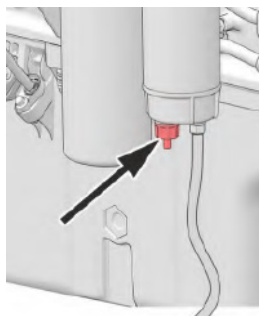

CHANGING THE FUEL FILTERS

The fuel system has a fine filter (A) and a pre-filter (B)

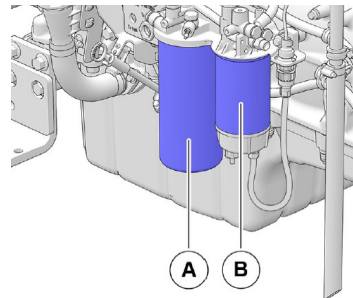

FUEL PRE-FILTER

- Remove the water separator sensor connector.
- Loosen the drain plug and drain water from the filter. Reinstall drain plug.
- Remove the pre-filter along with the water separator.
- Remove the lower section of the water separator and the o-ring from the filter.
- Clean the water separator, check the strainer for clogs.
- Install a new o-ring. Lubricate with diesel. Install filter to the water separator.
- Lubricate the sealing surface with diesel and screw new filter. Tighten the fuel filter in accordance with the instructions on the fuel filter.
- Reconnect the connector, Check for leaks.

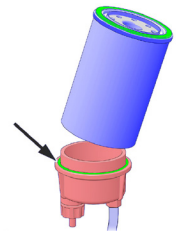

FUEL FILTER

- Clean round the fuel filter.
- Remove the filter with a suitable filter remover. Collect any spilled fuel in a collection vessel.
- Clean the filter mating surface on the filter bracket.
- Lubricate the seal with diesel fuel and install the new fuel filter. Tighten the fuel filter in accordance with the instructions on the fuel filter.

STORAGE

PREPARING THE ENGINE FOR A LONG PERIOD OF INACTIVITY

In the case of a planned period of inactivity that lasts longer than two months, to prevent the interior parts of the engine and some components of the injection system from oxidizing, prepare the engine as follows:

- Drain the lubricant oil from the sump after heating the engine.

2. Drain the engine oil and fill up with conservation oil to just over the MIN marking on the dipstick.
3. Connect the fuel suction and return hoses to a 1/3 full Jerrycan containing conservation oil and 2/3 diesel fuel.
4. Bleed the fuel system.
5. Start the engine and run at a fast idle until about 2 liters (0.6 US gal) of the fluid in the jerrican have been used. Stop the engine and re-connect the fuel suction and return lines.
6. Drain the conservation oil from the engine.
7. Make sure the coolant has adequate antifreeze properties. Top up as necessary. Alternatively, you can drain the coolant (also drain the coolant filter).
8. Drain any water and contamination from the fuel filters and fuel tank. Fill the fuel tank completely, to avoid condensation.
9. Disconnect the battery cables, clean and charge the batteries. Trickle charge the batteries while the equipment is in storage. A poorly charged battery can freeze and burst.
10. Put a note on the engine with the date, type of conservation and the conservation oil used.
11. Cover the air filter, exhaust pipe and engine if necessary.
12. Empty the AdBlue/DEF tank and rinse it with distilled water.

NOTE: When storing in cold regions, make sure the coolant and engine oil are in conditions suitable to the environment. Also, when starting the engine after it has been stored, make sure that there is no snow or foreign matter that could interfere with engine startup, and rotating parts are not frozen.

BRINGING OUT OF STORAGE

1. Remove any covers from the engine, air filter and exhaust pipe.
2. Fill the engine with the correct quality and viscosity oil into the engine, as necessary. Install a new oil filter if the filter was not changed during conservation.
3. Install new fuel filters and bleed the fuel system.
4. Check the drive belt(s).
5. Check the condition of all rubber hoses, and retighten the hose clamps.
6. Close the drain taps and install any drain plugs.
7. Check the coolant level. Top up as necessary.
8. Connect the fully charged batteries.
9. Start the engine and warm it up at fast idle with no load.

10. Check that no oil, fuel or coolant leakage occurs.

11. Fill the AdBlue/DEF tank. The solution must fulfill ISO 22241 standards.

MAINTENANCE SCHEDULE

SERVICE	INTERVALS
Check Engine Oil Level	Daily
Check Coolant Level and for Leakage	Daily
Check Air Filter	Daily
Check Electrolyte Level in Battery and Clean Terminals	6 Months
Drain Water from Fuel Pre-Filter	150 Hours
Check Belts and Belt Tension	300 Hours
Check Oil Vapor Filter	300 Hours
Change Oil	600 Hours
Change Oil Filters	600 Hours
Change Fuel Filters	600 Hours
Change Fuel Prefilter	600 Hours
Check Exhaust System for Damage	6 Months
Clean Fuel Tank	6 Months
Change Auxiliary Member Belt	1200 Hours
Change Air Filter (depending on conditions)	1200 Hours
Change Coolant	1200 Hours
Change Oil Vapor Filter	2 Years
Clean Turbocharger	1200 Hours
Adjust Play in Valve-Rocker Arms and Pump-Rocker Arms	1200 Hours

* There are additional maintenance items and explanations in the engine operator's manual. Read thoroughly before operating this unit.

TROUBLESHOOTING TABLE

Problem	Possible Causes
Unit will not crank when power fails	Digital genset not in AUTO Transfer control switch not in AUTOMATIC position Incorrect wiring between ATS and genset Defective control relay in ATS Fuse(s) blown in the DSE 7310 MKII Defective DSE 7310 MKII Loose or dirty battery terminals Defective starter Defective start solenoid Low/dead battery
Engine won't crank	Low/dead battery Blown DC fuses Defective DSE 7310 MKII Defective key switch Loose or dirty battery terminals Defective starter Defective start solenoid Locked up engine genset Defective engine harness Improper battery voltage to start solenoid, fuel pump, or fuel solenoid
Engine cranks but will not start	Improper fuel delivery to the unit Fuel supply shut off Fuel tank empty Air in the fuel system Engine fuel solenoid has not opened Defective fuel pump Defective fuel solenoid Defective engine harness Improper battery voltage to fuel pump or fuel solenoid
Engine starts, then stops and alarm light comes on	Engine oil pressure is low Engine has high water temperature Engine has overspeed Engine has gone into overcrank No output from AC generator Loss of speed signal Loss of run signal
Engine will not come up to speed after it starts	Insufficient fuel volume getting to the unit 1. Too small of fuel line 2. Fuel racks not open properly Governor is defective AC short in generator components
ATS will not transfer to Emergency Supply (generator)	No AC generator output Defective ATS control board. See ATS manual Circuit breaker open or defective
ATS will not re-transfer to normal power	Proper power line not available at line terminals in ATS panel Defective ATS control board. See ATS manual
No AC output from generator	Defective diode Defective voltage regulator Defective rotor Defective stator Defective exciter rotor Defective exciter stator AC short in the output leads Defective/open generator output breaker Wiring error

AVR WIRING

MX341 Automatic Voltage Regulator

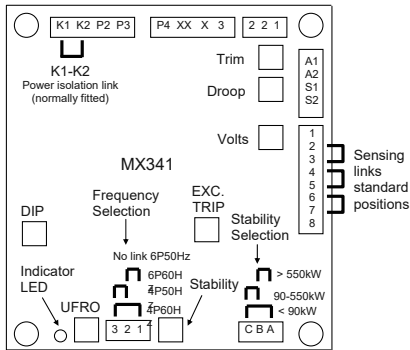

Under normal conditions only two adjustments are made to the voltage regulator.

VOLTS

To adjust generator output voltage.
Clockwise to increase voltage.

STABILITY

To prevent voltage hunting.
Clockwise to increase the dampening effect.

STANDARD CONNECTIONS

(Top Row, Right to Left)

1 - 2 Are linked together.

2 - Lead #9 from AC terminal block.*

3 - Lead #8 from AC terminal block.*

X - F1 from generator exciter

XX - F2 from generator exciter

P4, P3, P2 all come from the PMG

* voltage between these to leads must be between 190 & 264.

(Center tapped on 480 Volt)

WIRING SIZE TABLE

The table below is based on Table 310.15 (B) (16) un the National Electric Code 2014 edition. Allowable ampacitier of insulated conductrs rated 0 through 2000V, 75°C through 90°C. Not more than three current-carrying conductors in Raceway, Cable, or Earth (direct buried). Adjust for 40°C (104°F) ambient temperature.

Copper 75°C	Copper 90°C		Aluminum Copper Clad Alluminim 75°C	Aluminum Copper Clad Aluminum 90°
Wire Type: RHW, THHW, THW, THWN, XHHW, USE, ZW	Wire Type: TBS, SA, SIS, FEP, FEPB, MI, RHH, RHW-2, THHN, THHW, THW-2, XHH, XHHW, XHHW-2, ZW-2	SIZE AWG OR KCMIL	Wire Type: RHW, THHW, THW, THWN, XHHW, USE	Wire Type: TBS, SA, SIS, THHN, THW-2, THWN-2, RHH, RHW-2, USE- 2, XHH, XHHW, XHHW-2, ZW-2
44	50	8	35	41
57	68	6	44	55
75	86	4	57	68
88	100	3	66	77
101	118	2	79	91
114	137	1	88	105
132	155	1/0	106	123
154	177	2/0	119	137
176	205	3/0	136	159
202	237	4/0	158	187
224	264	250	180	209
251	291	300	202	232
273	319	350	220	255
295	346	400	238	278
334	391	500	273	319
370	432	600	299	350
405	473	700	330	382
418	487	750	339	396
431	505	800	348	410
458	532	900	374	437
480	560	1000	392	455
519	605	1250	427	496
550	642	1500	458	532
572	669	1750	480	560
585	683	2000	493	573

For additional information, see table 310.15 of the National Electric Code.

ENGINE SCHEMATIC

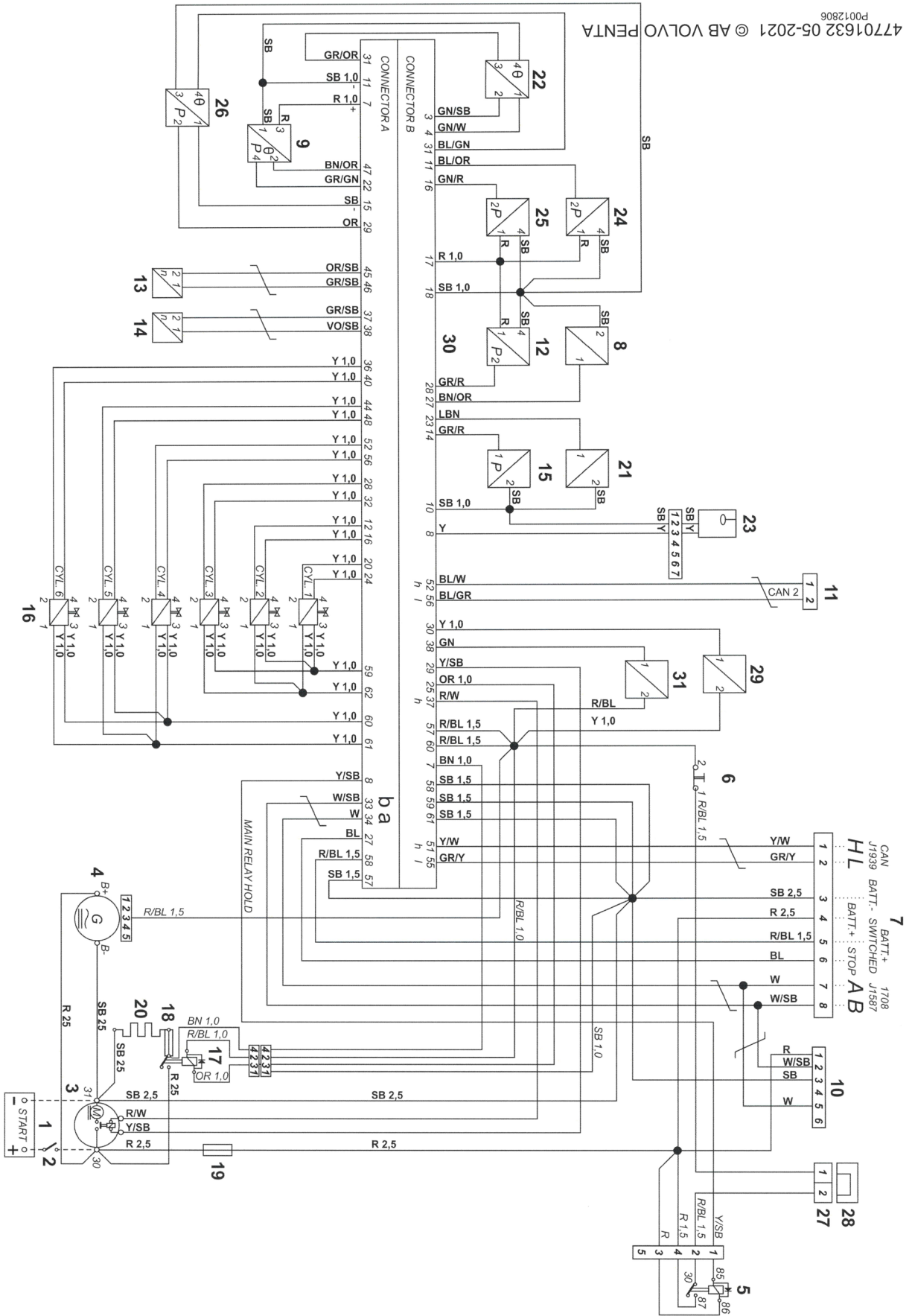

DSE 7310 MKII WIRING DIAGRAM

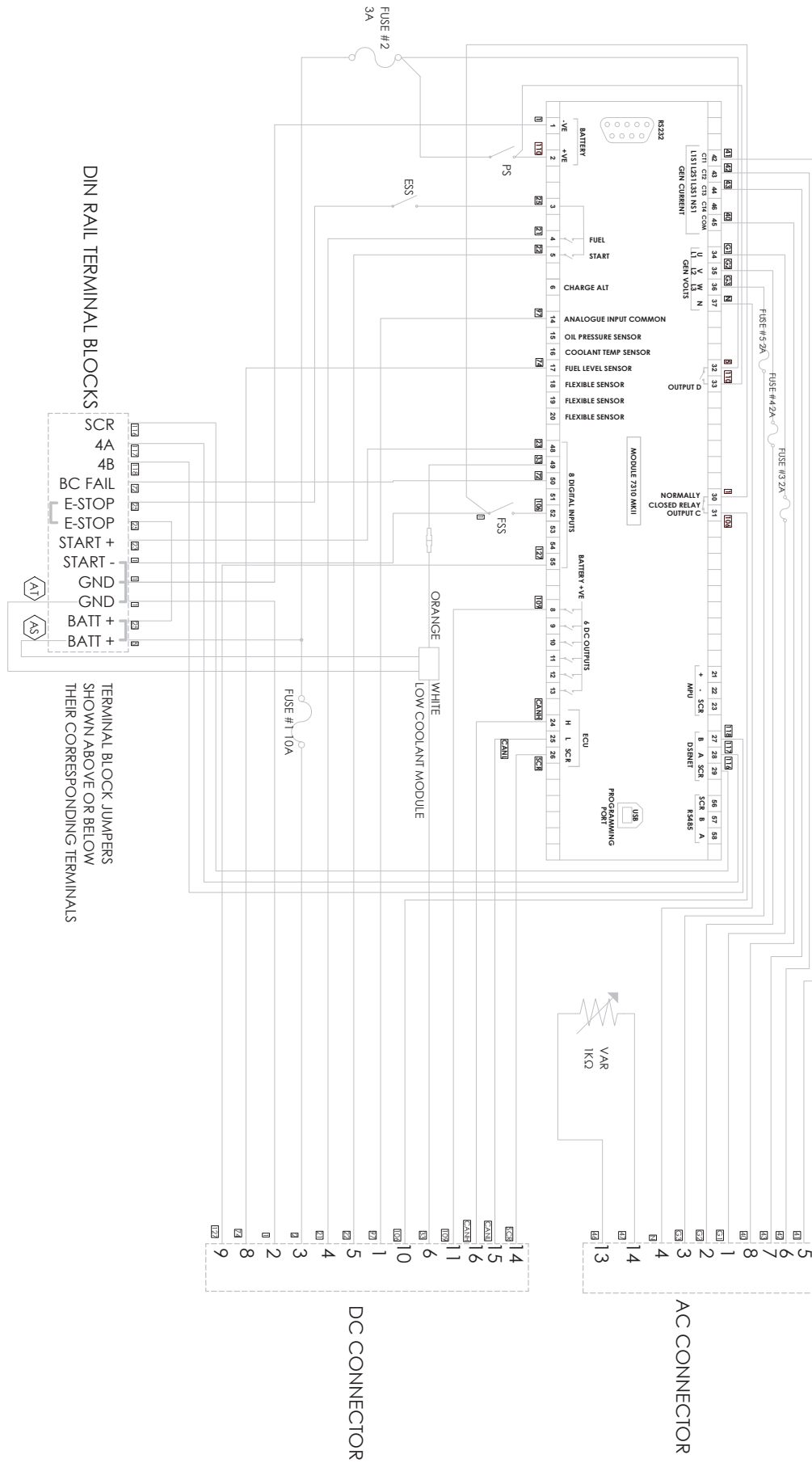

DIN RAIL TERMINAL BLOCKS

TERMINAL BLOCK JUMPERS SHOWN ABOVE OR BELOW THEIR CORRESPONDING TERMINALS

AC WIRING

THREE PHASE - HIGH WYE 277/480V

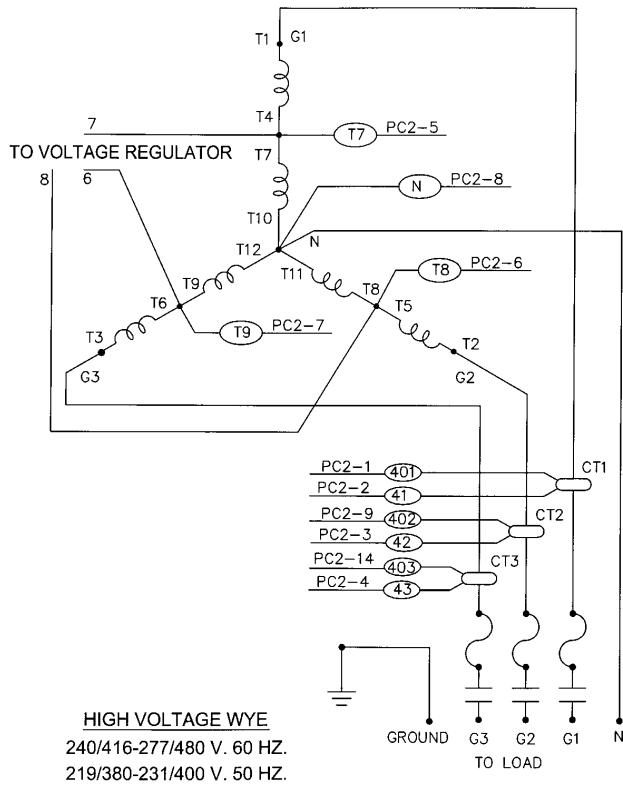

THREE PHASE - LOW WYE 120/208V

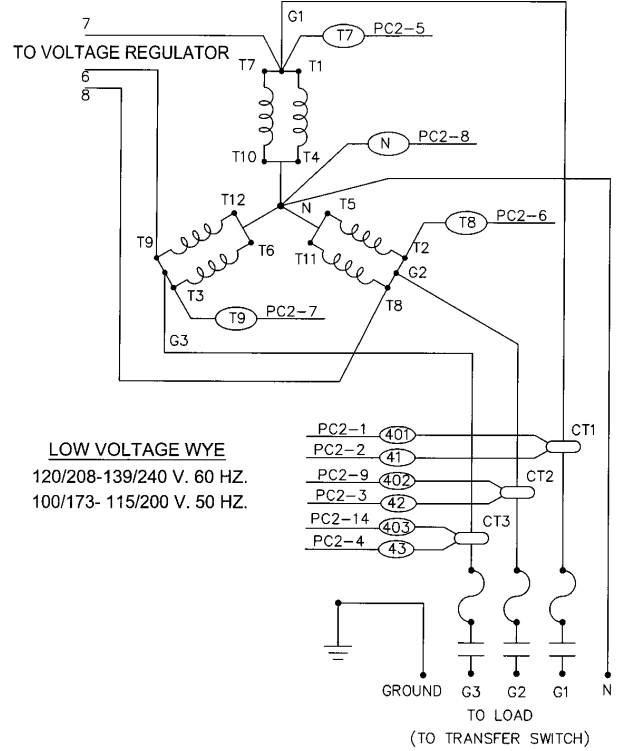

THREE PHASE DELTA 120/240V

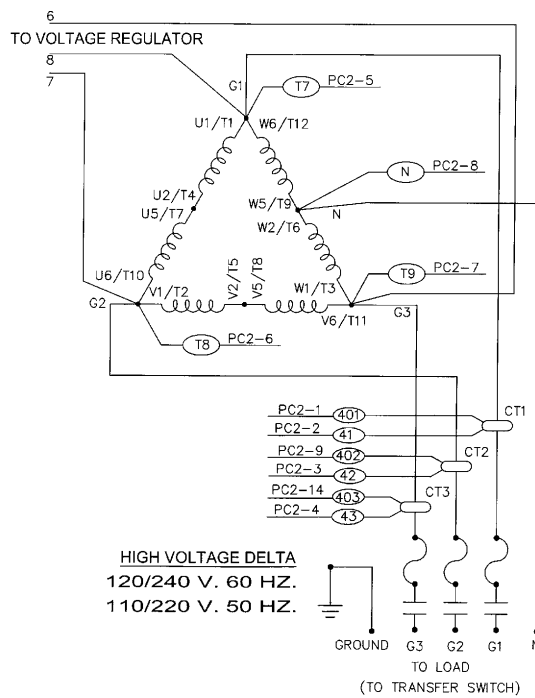

WARRANTY STATEMENT

WINCO Incorporated warrants to the original purchaser for the warranty period that goods manufactured or supplied by it will be free from defects in workmanship and material, provided such goods are installed operated and maintained in accordance with WINCO written instructions.

WINCO's sole liability, and Purchaser's sole remedy for a failure under this warranty, shall be limited to the repair of the product. At WINCO's option, material found to be defective in material or workmanship under normal use and service will be repaired or replaced. For warranty service, contact a Winco Authorized Service Center within the warranty period from date of purchase.

*NOTE: Units that are resold by original owner are not covered under this warranty. Any further warranty, whether expressed or implied, rests solely with the reseller.

THERE IS NO OTHER EXPRESS WARRANTY.

To the extent permitted by law, any and all warranties, including those of merchantability and fitness for a particular purpose, are limited to the warranty period from date of purchase. In no event is WINCO liable for incidental or consequential damages.

Note: Some states do not allow limitation on the duration of implied warranty and some states do not allow the exclusion or limitation of incidental or consequential damages, so the above limitations may not apply in every instance. This warranty gives you specific legal rights which may vary from state to state.

WINCO, INC. WARRANTY EFFECTIVE DATE

Air cooled units purchased for stock have 1 year to be sold. The warranty to the original retail customer commences on the date of sale of the product to them. All liquid cooled units have 180 days from the Winco invoice to submit a start up date. If no startup form is submitted, then warranty period starts on the Winco invoice date unit was sold.

Date of sale is defined as the day the customer takes delivery of the product. This warranty shall remain in effect to the original purchaser for the period stated on the sales literature. The warranty is not transferable and the retail customer must retain his original bill of sale as proof of purchase date.

WINCO, Inc. agrees to the following obligations during the warranty period:

1. To warrant any defect in material or workmanship of products sold under the WINCO and DYNA brand names in accordance with the warranty statements in the operator's manuals.
2. To reimburse authorized WINCO, Inc. Service Centers/Dealers for the cost of parts plus standard ground UPS shipping charges for all valid warranty repairs and to reimburse same said service centers/dealers for reasonable labor charges based on WINCO's current warranty labor reimbursement rate.
3. To furnish its authorized service centers/dealers with the necessary parts to make the repairs. WINCO Generator Warranty Periods & Restrictions

WINCO GENERATOR WARRANTY PERIODS & RESTRICTIONS

Industrial Portables

WL Models - 3 Years, See Notes 1 & 2

W Models - 3 Years, See Notes 1, 2, & 5

DP Models - 3 Years, See Notes 1 & 2

HPS Models - 2 Years, Home Use ONLY; Commercial use* is 90 Day Warranty, See Note 1

EMERGEN-C (EC) Series

2 Years, See Note 1

DE Series

1 Year/2000 hours, No Travel Time

Mobile Diesel Series

1 Year/2000 hours, No Travel Time

PTO Series

15kW & 10kW - 1 Year, Limited Farm Standby Only

25kW thru 165kW - 3 Years, Limited Farm Standby Only/Commercial use* 1 Year

Two Bearing Series

1 Year, Bench Labor and Parts only

Gaseous/Packaged Standby Series (PSS)

Air-Cooled Models (PSS8, PSS12, & PSS20) – 2 Years/2000 Hours Standby Only See Notes 3 & 4 Prime Power use 1 Year/2000 Hours See Notes 3 & 4

Liquid-Cooled Models (PSS21 - PSS150) - 2 Years/2000 Hours Standby Only See Notes 3 & 4 Prime Power use 1 Year/2000 Hours See Notes 3 & 4

Diesel Standby Series (DR)

Liquid-Cooled Models (DR12 - DR600) - 2 Years/2000 Hours Standby Only See Notes 3 & 4

Prime Power use 1 Year/2000 Hours See Notes 3 & 4

Accessories (Installed on Generator or shipped loose)

1 Year from factory invoice or 2000 Hours (whichever occurs first)

Automatic Transfer Switches (ATS)

See ATS Manufacturer's Warranty

NOTES

Note 1: First 2 years of warranty coverage includes Parts and Bench Labor Only, no travel time or labor allowance for removal or reinstallation of the product from its application.

Note 2: 3rd Year warranty coverage is parts only/no labor.

Note 3: Round trip mileage is limited to 200 miles per trip and a total of 2 trips per repair unless authorized in writing by the WINCO Service Dept.

Note 4: Mileage allow on permanently installed units only. Trailer mount units is bench labor only.

Note 5: W3000 is a 1 Year Warranty.

*Commercial use is defined as Construction, Rental, Prime Power, or use in a business of any type including agricultural and hobby. Prime Power use is defined as any application where the generator set is being used 'off-grid' where there is no utility power present. Standby use is defined as an application where utility power is present -and- the generator set is used as emergency backup during utility power outages.

WINCO reserves the right to change or improve it's products without incurring any obligations to make such changes or improvements on products purchased previously.

EXCLUSIONS:

WINCO does not warrant Engines. Engines are covered exclusively by the warranties of their respective manufacturers.

WINCO does not warrant Batteries, or Other Component Parts that are warranted by their respective manufacturers.

WINCO does not warrant modifications or alterations which were not made by WINCO, Inc.

WINCO does not warrant products which have been subjected to misuse and/or negligence or have been involved in an accident.

This warranty does not include travel time, mileage, or labor for removal or reinstallation of WINCO product from its application, unless specifically authorized.

WHAT IS COVERED BY WARRANTY

1. Generator end including rotor, stator, end brackets, and bearing.
2. Control box including transformers, circuit breakers, wiring, resistors, and switches.
3. LP/NG fuel system including fuel solenoid, demand regulator, carburetor, and hoses.
4. Cradle assembly including cradle, cross member, and shock mounts that fail. Shock mounts damaged from rough handling are not covered.
5. Reasonable travel time for the PSS & DR series generators only, that are permanently installed.
6. Ground shipping charges for warranty parts, no premium service, domestic US shipments only.

WHAT IS NOT COVERED BY WARRANTY

1. Products which have been subjected to alteration, modification, neglect or unauthorized repairs not approved in writing by Winco, Inc.
2. Products no longer owned by the original purchaser.
3. Products with shipping or freight damage. File a freight claim with the delivery carrier.
4. Products suffering normal wear, accidents, improper maintenance or improper protection in storage. Products damaged by rough handling, such as shock mounts on cradle assemblies.
5. Pressure or steam cleaning of products, cleaning of fuel system, or flushing of cooling system.
6. Replacement of filter, belts, antifreeze, or lubricants.
7. Electrical items, such as light bulbs, receptacles, spark plugs, or any items damaged by welding or jump starting.
8. Any repeat or shop come-back repairs resulting from poor service work or improper diagnosis and testing. Replacement of parts as a trial-and-error method of diagnosis will not be considered for warranty.
9. Replacement parts other than those sold by Winco, Inc.
10. Damage caused by fire, flood, lightning or any other natural disaster.
11. Damage caused by improper protection during installation, (i.e. not protecting contactor in the ATS panel and getting wire trimming or debris from drilling the box in the contactor coil or contacts.)
12. Damage caused by over loading of the generator and failure to adequately provide overload protection.
13. LP/NG fuel adjustments or conversion from one fuel to another.
14. Adjustment of any kind, all units are 100% load tested before shipping.
15. Any damage caused by the use of the equipment for purposes other than for which it was designed.
16. Engines - All engines used by Winco, Inc. are warranted by their respective manufacturer's.
17. Batteries - Must be returned to original battery manufacturer.
18. Damage caused by improper installation or failure to provide adequate ventilation.
19. Cosmetic repairs, such as repainting.
20. Freight charges for transportation to and from a Warranty Service Center.
21. Rental costs of renting replacement generators.
22. Travel time or service calls unless specifically authorized by Winco, Inc. in writing.

GENERAL INFORMATION

The WINCO, Inc. Service Department is open from 7:30 AM to 4:30 PM Central Standard time.

It is located at 225 South Cordova Ave., Le Center, MN, 56057-1805. Phone Numbers: Service Department - 507-357-6831 FAX Line - 507-357-4857. Email address is service@wincogen.com The phone number to for the General Switchboard/Sales Department is 507-357-6821.

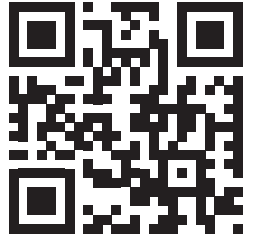

WINCO[®]
GENERATORS



AN AMERICAN COMPANY

225 S. CORDOVA AVE • LE CENTER, MN 56057

Sales: 507-357-6821 • sales@wincogen.com

Service: 507-357-6831 • service@wincogen.com

www.wincogen.com

