

INSTALLATION AND OPERATORS MANUAL

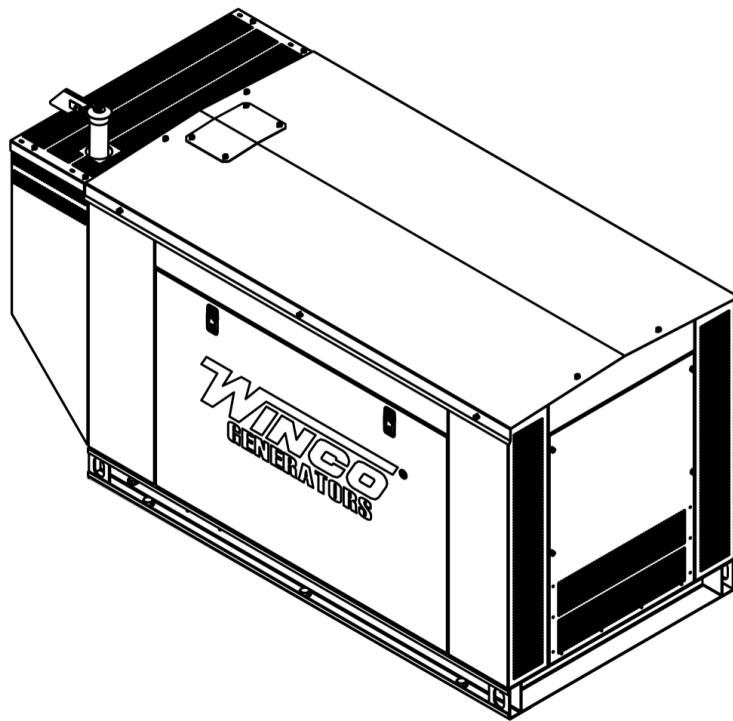

COPY YOUR MODEL AND SERIAL NUMBER HERE
No other WINCO generator has the same serial number as yours.
If you should ever need to contact us on this unit, it will help us to
respond to your needs faster.

MODEL _____

SERIAL NUMBER _____

PURCHASE DATE _____

DEALER NAME _____

DEALER PHONE # _____



TABLE OF CONTENTS

SAVE THESE INSTRUCTIONS

SAVE THESE INSTRUCTIONS

SAFETY INFORMATION

ANSI SAFETY DEFINITIONS

SPECIFICATIONS

DR2014

INTRODUCTION

TESTING POLICY

PRODUCT DESCRIPTION

PREPARING THE UNIT

START-UP CHECK LIST

UNPACKING

LIFTING THE GENERATOR SET

INSTALLATION

VENTILATION REQUIREMENTS

EXHAUST INSTALLATION

INSTALLING THE FUEL LINE

A.C. ELECTRICAL CONNECTIONS

GROUNDING

D.C. ELECTRICAL CONNECTIONS

INSTALLING THE BATTERY

BATTERY CHARGER & BLOCK HEATER

STARTING PROCEDURE

LUBRICATION

COOLANT

PRE-START CHECK LIST

CONTROL LAYOUT

MANUAL MODE

AUTO MODE

CONTROL POWER

OPERATING CONDITIONS

NORMAL OPERATION

HARSH ENVIRONMENTS OPERATIONS

COLD WEATHER OPERATIONS

MAINTENANCE

CHANGING THE OIL

CHANGING OIL FILTER

CHANGING COOLANT

REFILLING COOLANT

CHANGING AIR FILTER

CHECKING WATER IN FUEL FILTER

CLEANING RADIATOR

CHANGING THE FUEL FILTER

STORAGE

MAINTENANCE SCHEDULE

TROUBLESHOOTING TABLE

WIRING SIZE TABLE

ENGINE HARNESS SCHEMATIC

DSE7310 WIRING DIAGRAM

WIRING DIAGRAMS

LIMITED WARRANTY

2	This manual contains important instructions that should be followed during installation and maintenance of the generator. Read and understand all instructions in the manual before starting and operating the generator.
3	
4	USING THIS MANUAL Congratulations on your choice of a WINCO generator. You have selected a high-quality, precision-engineered generator designed and tested to give you years of satisfactory service.
5	
6	To get the best performance from your new generator, it is important that you carefully read and follow the operating instructions in this manual.
7	Should you experience a problem please follow the "Troubleshooting Tables" near the end of this manual. The warranty listed in the manual describes what you can expect from WINCO should you need service assistance in the future.
12	
13	
15	
16	
19	
20	
21	
22	
23	
24	

SAFETY INFORMATION

This engine generator set has been designed and manufactured to allow safe, reliable performance. Poor maintenance, improper or careless use can result in potentially deadly hazards; from electrical shock, exhaust gas asphyxiation, or fire. Please read all safety instructions carefully before installation or use. Keep these instructions handy for future reference. Take special note and follow all warnings on the unit labels and in the manuals.

CALIFORNIA PROPOSITION 65



WARNING: This product contains crude oil, gasoline, diesel fuel and other petroleum products, Antifreeze to which can expose you to chemicals including toluene and benzene, Ethylene glycol (ingested) which are known to the State of California to cause cancer, birth defects or other reproductive harm and developmental issues.
For more information go to www.P65Warning.ca.gov.

ANSI SAFETY DEFINITIONS

DANGER

DANGER indicates an imminently hazardous situation which, if not avoided, will result in death or serious injury. This signal word is to be limited to the most extreme situations.

WARNING

WARNING indicates a potentially hazardous situation which, if not avoided, could result in death or serious injury.

CAUTION

CAUTION indicates a potentially hazardous situation which, if not avoided, may result in minor or moderate injury. It may also be used to alert against unsafe practices.

1. ELECTRICAL SHOCK -

The output voltage present in this equipment can cause fatal electric shock. This equipment must be operated by a responsible person.

- Do not allow anyone to operate the generator without proper instruction.
- Guard against electric shock.
- Avoid contact with live terminals or receptacles.
- Use extreme care if operating this unit in rain or snow.
- Use only three-pronged grounded receptacles and extension cords.
- Be sure the unit is properly grounded to an external ground rod driven into the earth.

2. FIRE HAZARD -

Gasoline and other fuels present a hazard of possible explosion and/or fire.

- Do not refuel when the engine is running or hot.
- Keep fuel containers out of reach of children.
- Do not smoke or use open flame near the generator

set or fuel tank.

- Keep a fire extinguisher nearby and know its proper use. Fire extinguishers rated ABC by NFPA are appropriate.
- Store fuel only in an approved container, and only in a well ventilated area.
- Follow local codes for closeness to combustible material.

3. DEADLY EXHAUST GAS -

Exhaust fumes from any gasoline engine contain carbon monoxide, an invisible, odorless and deadly gas that must be mixed with fresh air.

- Operate only in well ventilated areas.
- Never operate indoors including attached garages
- Never operate the unit in such a way as to allow exhaust gases to seep back into closed rooms (i.e. through windows, walls, floors).

4. NOISE HAZARD -

Excessive noise is not only tiring, but continual exposure can lead to loss of hearing.

- Use hearing protection when working around this equipment for long periods of time.
- Keep your neighbors in mind when using this equipment.

5. CLEANLINESS -

Keep the generator and surrounding area clean.

- Remove all grease, ice, snow or materials that create slippery conditions around the unit.
- Remove any rags or other materials that could create a potential fire hazard.
- Carefully clean up any gas or oil spills before starting the unit.

6. SERVICING EQUIPMENT -

All service, including the installation or replacement of service parts, should be performed only by a qualified technician.

- Use only factory approved repair parts.
- Do not work on this equipment when fatigued.
- Never remove the protective guards, covers, or receptacle panels while the engine is running.
- Use extreme caution when working on electrical components. High output voltage from this equipment can cause serious injury or death.
- Always avoid hot mufflers, exhaust manifolds, and engine parts. They can cause severe burns instantly.
- The use of the engine-generator set must comply with all national, state, and local codes.

SPECIFICATIONS

DR2014

Generator

	DR2014-03	DR2014-04	DR2014-17	DR2014-18
Wattage	20,000	20,000	20,000	20,000
Volts	120/240	120/208	120/240	277/480
Phase	Single	Three	Three	Three
PF	1.0	.80	.80	.80
Amps	83	69	60	30
CB Size	90	75	60	30
Hertz	60	60	60	60

Engine

Model	Isuzu 4LE2 2.2L
Starting System	12 Volt
Muffler	Standard
Fuel Consumption (full load)	2.1 Gal/Hr

GENERATOR RESISTANCE (all value at 22°C)

Model	Stamford SOL2-M1
Winding Group	
Single Phase	706
Three Phase	711
Rotor	0.747 Ω
Stator	
Single Phase	0.097 Ω per phase series star connected
Three Phase	0.290 Ω per phase series star connected
Exciter Rotor	0.106 Ω per phase
Exciter Stator	15.42 Ω

ENGINE

Model	Isuzu 4LE2
Starting System	12 Volt
Fuel Consumption (full load)	1.8 Gal/hr
Fuel	ASTM D-975 - 2D*
Oil Type	See Lubrication section
Oil Capacity	8.6 Quarts
Cooling System	50/50 mix

* See engine manual for additional fuel types and specifications

INTRODUCTION

TESTING POLICY

Before any generator is shipped from the factory, it is fully checked for performance. The generator is loaded to its full capacity, and the voltage, current, and frequency are carefully checked.

Rated output of generator is based on engineering tests of typical units, and is subject to, and limited by, the temperature, altitude, fuel, and other conditions specified by the manufacturer of applicable engines.

PRODUCT DESCRIPTION

The engine-generator set consists of a multi-cylinder, liquid-cooled engine nominally operating at 1800 RPM. This generator set meets current EPA regulations for standby use only. The generator frequency regulation is maintained by the engine mechanical governor to within +/- 1.5 Hertz. The generator is connected to the engine flywheel via flexible drive disks. The generator set is skid mounted with isolation mounts between the engine and base.

NOTICE:

A Customer supplied 12 Volt battery is required to complete the installation. Battery requirements are listed later under the battery installation section.

The generator ships with an advanced DSE7310 digital controller. The DSE7310 will electronically display useful engine and generator performance information. The controller starts and stops the generator and monitors critical operating parameters and will shut the generator down to protect the engine from damage.

GENERATOR SET:

Every WINCO generator set has its own unique identity data plate. This data plate identifies the complete unit model number, the system serial number, and has links to the individual components that form the generator set in our factory records. Several of the major components also have their own individual data plates providing additional information to document build data for warranty and replacements parts. Be sure to have the main WINCO unit data plate information recorded inside the front cover of this manual for future reference and for identification whenever requesting field or factory assistance.

Primary fields needed for assistance are complete model number and serial number.

ENGINE:

This manual covers specific operation of the combined engine generator set. The basic engine information provided in this manual is not suitable for all operating conditions. Refer to the engine operators manual for more detailed operation and maintenance information.

The engine manufacturer has established an excellent worldwide engine service organization; engine service is available from a nearby authorized dealer or distributor.

The rated power of each engine-generator is limited by the temperature, altitude, and all other ambient conditions specified by the engine manufacturer.

Derates	
Above Sea Level	3% PER 1,000 Feet
Ambient Temperature >104°F	3% per 10°F

Units should not be operated in ambient temperature greater than 125° Fahrenheit.

GENERATOR:

The nameplate includes a standby rating. The standby rating is the maximum amount of power the generator set can produce.

WINCO generator sets use a brushless, AVR (Auto-Voltage Regulator) controlled broad-range generator ends. The generator converts rotational mechanical energy into electrical energy. These WINCO units are equipped with generators manufactured by Cummins Generator Technologies. Each generator 'end' has its own data tag. A unique serial number is on the data plate and the data label is affixed to the main frame on the generator on the left side.

CAUTION: EQUIPMENT DAMAGE

Be sure to check the engine oil level frequently as specified in the engine manual.

PREPARING THE UNIT

START-UP CHECK LIST

A Start-Up Completion & Warranty Validation Form was sent along with this manual. This must be completed and returned to WINCO Inc. within 180 days of the factory invoice date. If this form is not returned, the Warranty may be voided.

UNPACKING

1. As you receive your unit, it is critical to check it for any damage. If any damage is noted, it is always easiest to refuse the shipment and let WINCO take care of the freight claim. If you sign for the unit, the transfer of the ownership requires that you file the freight claim
2. Before proceeding with the preparations of your new generator for operation, take a couple of minutes to ensure the unit you have received is the correct model and review the specification pages in this manual to ensure that this unit meets your job requirements.

CAUTION: EQUIPMENT DAMAGE

This unit is shipped with oil and a 50/50 mix of coolant. Be sure to check all fluid levels before operating. See engine manufacturer's instruction manual for recommended oil requirements before initial starting.

Once generator set is on-site:

1. Carefully remove the crate.
2. After inspecting the engine-generator for external, physical damage, locate and check the following items packed with the unit:
 - a. Installation and Operator's Manual.
 - b. Engine manufacturer's instruction manual.
 - c. Battery hold-down brackets & hardware.
 - d. Unit components or accessory items shipped loose for on-site installation.
 - e. Optional accessories.
3. Remove main frame hold-down bolts.
4. Unit can now be lifted from shipping rails.

LIFTING THE GENERATOR SET

NOTICE: PERSONAL INJURY

To prevent injury to persons or equipment, observe the following guidelines when lifting the generator:

Due to the different designs, configurations, options, weights, site conditions, and available material handling equipment, specific lifting instructions are not provided for each individual generator set model. General guidelines provided are applicable to the entire generator line. It is the responsibility of the installing party to follow the lifting equipment's operator's manual to prevent injury to personnel and damage to the generator.

Smaller generator sets may not require use of overhead lifting equipment and may be placed on the pad with basic material handling equipment, i.e. a forklift. Always use forklifts of a proper rating and with long enough forks to

move the generator. As the distance from the forklift mast increases the lifting capacity for the forklift decreases. When lifting from the side the forks should extend the entire width of the unit to the opposite side frame rail.

CAUTION

Do not attempt to lift the generator set by the means of the lifting eyes on the engine or generator end. These lifting points are only for the use during the manufacturing process and are designed for lifting of the individual generator set components.

WARNING

NEVER attempt to lift the fuel tank filled with fuel. Sloshing of the fuel can cause a shift in the balance of the fuel tank, making for a DANGEROUS, unbalanced lifting load. If the generator was shipped on the fuel tank, use the lifting points located on the fuel tank to move the entire generator set into place. DO NOT PLACE FUEL IN THE TANK PRIOR TO LIFTING.

INSTALLATION

This unit should be installed in a well ventilated area, ensuring the exhaust air cannot be recirculated back into the engine.

CAUTION

This unit will get hot while it is running and for some time afterward.

WARNING: PERSONAL INJURY

Before proceeding with the installation, be sure the engine control is in the "stop" position and the emergency stop depressed. Also, be sure the generator MLCB (main line circuit breaker) is in the "off" position and the unit starting battery is disconnected.

GENERAL INFORMATION

Before beginning the installation process, recheck the voltage, phase, and amperage rating of the generator set. Be certain it can handle the intended load and are compatible with the intended loads. Plans for installation should be prepared with proper attention to mechanical and electrical engineering detail to assure a satisfactory system installation.

The information in this manual is offered only as a guide to finalizing your installation plans.

NOTICE: For full service switching of the entire load, the ATS must be 'SE' (Service Entrance) rated or must have a properly rated fusible disconnect installed before the ATS to protect the contacts.

ENGINE GENERATOR SET MOUNTING

This engine-generator set is generally supplied as weather enclosed packages for quick installation on an outdoor concrete pad. They are also available as open skid mounted units for indoor installation in a building or protective enclosure, properly ventilated, supplied by the installer.

The factory weather enclosures are acoustical housing intended for outdoor installation only. Factory weather enclosed units are not intended to be used indoors and no support is available to assist in re-engineering finished packaged units. The unit should be mounted to allow ample working room around it. A general rule to follow is to allow 24 inches or more of clearance for maintenance. Follow local codes for clearance from combustible surfaces.

The unit's main frame must be bolted securely to a solid base. The engine-generator is mounted on channels which are attached with special shock mounts to the main frame. This allows the engine-generator free movement without affecting the base or surrounding equipment.

WARNING: EQUIPMENT DAMAGE:

Never mount these engine-generator sets to a wooden base/structure. Over time, the wood will deteriorate and the unit mountings will come loose. These units must be mounted to a steel or concrete base.

VENTILATION REQUIREMENTS

OPEN SKID

WARNING: EQUIPMENT DAMAGE

It is the installer's responsibility to ensure that there is sufficient cooling air available to prevent the engine and generator from over heating. Damage caused by overheating is not covered by warranty.

Providing proper air movement during your installation planning is essential. You will need to provide a fresh air inlet as well as a hot air outlet (to the outside of protection housing) for proper engine performance. These engine-generator sets are equipped with unit mount radiators and the engine is equipped with a pusher type fan. The hot air from the face of the radiator must be ducted out of the enclosure to ensure proper cooling. Failing to do so will allow the hot air to recirculate around the radiator causing the engine to overheat, resulting in an engine shutdown and damage. If louvers are used in front of the hot air duct to protect the unit from outside weather, the louvers should be 1 ½ times as large as the area of the radiator face to prevent back pressure.

Foam or other seals can be used to form a tight lip forcing all of the air from the engine fan out of the enclosure. In addition to a hot air discharge, you must plan a fresh air intake opposite the radiator discharge. Their fresh air inlets should be 1 ½ to 2 times larger than the radiator face. The extra air inlet area is required to minimize restriction and to provide combustion air for the engine. Do not block fresh air intakes with other equipment as this will result in insufficient air flow to the engine for cooling. Installing them opposite the hot air discharge will allow a sweeping flow of cooling air across the engine, preventing hot spots.

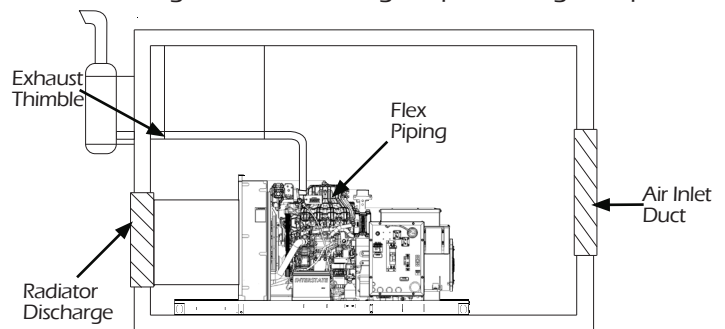

The WINCO installation manual OPM-112 contains additional information on indoor, open skid installations and is available electronically through our website or by requesting a copy from the factory.

EXHAUST INSTALLATION

WARNING: PERSONAL INJURY

Improper exhaust installation will allow dangerous gases to seep into enclosed spaces causing a hazard to your health and/or death.

All exhaust must be piped out of the enclosure. When selecting a location to exhaust fumes make sure that the

potential for contact with people is controlled. Exhaust can enter buildings through windows, ventilation systems and other openings if proper precautions are not followed.

The exhaust must be isolated from the vibration of the engine. If the exhaust is connected in a rigid system it will result in damage to the engine. The generator comes equipped with an engine mounted flex pipe to aid your installation. Ensure proper alignment with the generator. The flex can be eliminated if it is pushed to one side to make a connection.

The most direct path possible should be used to get to the outside of the enclosure. Each bend restricts the pipe and increases back pressure. It may be necessary to increase the exhaust pipe diameter in some applications.

The exhaust pipe is very hot. When passing through the structure it is critical that a thimble or other appropriate technique is used to dissipate the heat and prevent the structure from catching on fire.

It is preferable to exhaust out the side of the enclosures. Slope the pipe slightly downward away from the engine to cause any water in the exhaust to run away from the engine. Do not exhaust near intake. Once outside the enclosure a rain cap or other technique must be used to keep water out of the exhaust. In mobile applications make sure the rain flap faces to the rear of the vehicle so that it is not blown open during transportation.

The generator ships with a critical grade muffler that should be installed to decrease noise. It can be mounted either internally or externally to the enclosure. The muffler cannot increase back pressure to more than 0.725 psi.

INSTALLING THE FUEL LINE

WARNING: FIRE DANGER

Connecting rigid fuel line (i.e. steel or copper line) directly to the inlet fuel filter or fuel pump may cause the fuel line to crack during operation creating a serious fire hazard.

The fuel supply should be as close to the engine as possible. This will reduce the installation cost of fuel runs and minimize line losses. The diesel fuel supply should be no more than 3 feet below the fuel inlet on the pump. If your fuel supply is lower than three feet you may have to install an additional lift pump to bring the fuel up to the mechanical fuel pump on the engine.

The information in this manual is offered to assist you in providing the proper fuel for your engine. However, this information is only provided to inform you of the engine's requirements and assist in making you aware of the decisions you must make. In no case should the instructions or information provided be interpreted to conflict with any local, state, or national codes. If in doubt, always consult your local fire marshal or fuel supplier.

Engine generator sets are properly adjusted before they leave the factory. Connecting a fuel supply with adequate supply volume is critical to reliable operation. Diesel units with optional base mounted fuel tanks are pre-plumbed to the mechanical fuel pump on the engine.

Open skid mounted Diesel units are often supplied with capped inlet and return lines. The use of a sustainable customer supplied flexible fuel line is essential between the engine and fuel supply to provide a vibration break between your fuel supply and the engine.

A.C. ELECTRICAL CONNECTIONS

NOTICE: CLASS 1 WIRING METHODS ARE TO BE USED FOR ALL FIELD WIRING CONNECTIONS TO TERMINALS OF A CLASS 2 CIRCUIT

WARNING

A mainline circuit breaker has been provided inside the generator housing. During all wiring installation, make sure the breaker is in the off position and the generator is disabled.

WARNING:

Make sure the generator is disconnected from the battery to prevent accidental starting.

The connection box shown are typical arrangements.

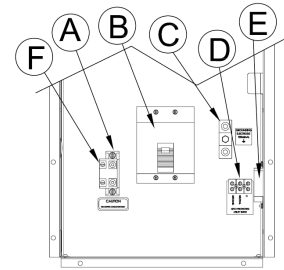

A. NEUTRAL LUGS:

These lugs are isolated from ground and provided for you to connect your neutral wire from the transfer switch to the generator.

The 225 Amp terminal block lugs will handle wire size #4 to 300 MCM and should be torqued to 250 in. lbs.

B. GENERATOR CIRCUIT BREAKER:

This circuit breaker provides overload protection for the generator. Your power feeds from the transfer switch will connect the bottom lugs on the circuit breaker. The generator power feeds have already been wired into the upper lugs.

Please refer to the circuit breaker installed on your unit for breaker lug capacities and proper torque specifications.

To select the proper conductor size between the generator and the ATS, first look your model up in Table 1 of Appendix "A" for your generator amperage, found further in this manual. Then refer to Appendix "2" for guidance on wire sizing based on both wire type and amperage.

For additional information on wire sizes, refer to table 310-16 of the National Electrical Code ANSI/NFPA 70.

C. GROUND LUG:

These ground lugs are bonded to ground and are provided for you to connect your ground wire from the transfer

switch to. The lugs will accommodate #10 AWG to 2/0 AWG and should be torqued to 200 in. lbs.

D: 120V GFCI CIRCUIT TERMINAL BLOCK:

These terminals are rated for 85 Amps and will handle wire sizes #4 AWG to 18AWG. They should be torqued to 16 in. lbs. This circuit must be fed from a fused circuit in the distribution panel and provides power for the block heater and the battery charger.

E: 120V/20 AMP DUPLEX RECEPTACLE:

This convenience receptacle is used to power both battery charger and block heater. This circuit must be fed from a GFCI fused circuit in the distribution panel.

F: NEUTRAL TO GROUND LEAD LUG:

This lug is provided on the neutral terminal block to allow you to run a neutral to ground lead if you are using the generator in a stand alone application. This would be an application where there is not a distribution panel and no other ground to neutral bond in the wiring system. If a grounding wire is attached here, remove the floating neutral label in the panel. This will not be used when you are wiring a generator and transfer switch into an existing power system.

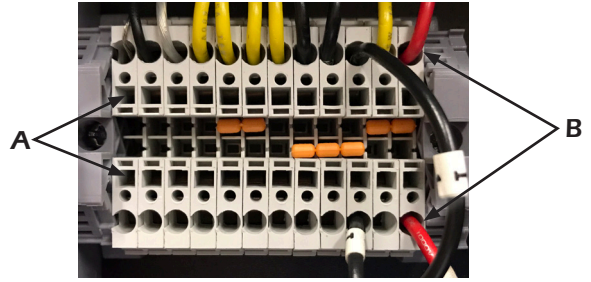

REMOTE START

The DSE7310 is able to start the generator when it receives a remote signal from any dry contact. This makes the system compatible with a wide range of control mechanisms including two-wire start automatic transfer switches. When the contact closes the controller will automatically start. When the contact is opened the generator will go through a cool-down cycle and turn off. Connect the remote start leads to the Remote Start + and Remote Start - terminal blocks in the door behind the DSE 7310 controller.

Depending on the distance, 14 to 16 gauge stranded wire should be used. It is suggested that these wires be labeled S1 and S23.

Note: Any relay closure can be used to start and stop this generator. As long as the contact stays closed the engine generator set will continue to run. Once the relay is opened the unit will shut down and remain in the standby mode until the remote start relay is closed again.

WARNING

A mainline circuit breaker has been provided inside the generator housing. During all wiring installations, make sure the breaker is in the OFF position and the generator operating switch is in the OFF position.

WARNING: EQUIPMENT DAMAGE

When installing a three-phase 240 Volt system, be sure you know which lead is the high voltage "wild" leg (208 Volt line to neutral). The generator normally carries the high voltage on the G2 lead.

All wires should be installed in rigid or flexible conduit (knockouts are provided in the control box).

GROUNDING

A grounding lug has been provided on the engine generator set and the generator set must be properly grounded to good earth ground. Generally an 8 foot copper rod driven into the earth will provide a proper earth ground.

D.C. ELECTRICAL CONNECTIONS

All DC connections are completed on the terminal strip just below the engine control. All DC connection must be separate conduit. You cannot mix AC and DC leads at the same conduit.

CONNECTION BOX TERMINALS

To install the wires, reference the following picture. Use a small flat head screwdriver to push the release spring inside the square hole (A). While the release is being pushed, insert the wire into the larger circular hole (B). Remove the screwdriver to secure the wire into place.

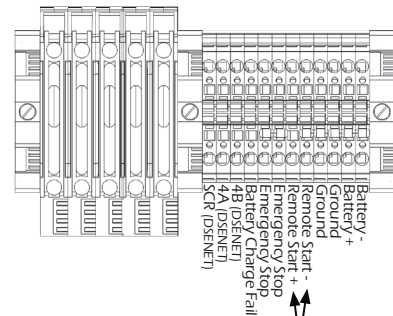

Two-Wire Start Hook-Ups

E STOPS

In some applications additional emergency stops may be desired or necessary. The controller has terminals designed allowing the addition of multiple remote emergency stops. E-stops must be normally closed to work properly in this system. The e-stop circuit supplies power to fuel solenoid and the starter circuit. Opening any switch in the series prevents the engine from cranking or from receiving fuel to run.

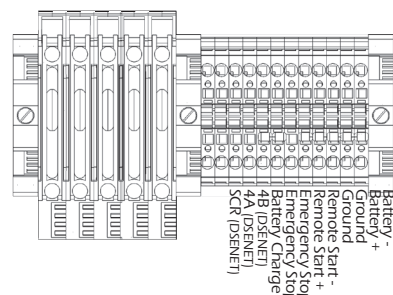

E-Stops

To wire additional emergency stop switches first remove the orange jumper between the two Emergency Stop terminal blocks. Failure to remove the jumper will prevent the remote switches from working properly. Add wires between the terminal block to the new switch(s). The switches must be wired in series for proper function. Test each e-stop after wiring to ensure they function properly.

SERIAL COMMUNICATION

DSE provides a series of remote accessories that can help provide useful information to operators. These accessories communicate over the DSE Net. Terminal blocks are wired to the distribution panel to aid in installation. Follow the instructions included with each accessory.

The generator controller can communicate with a variety of controls and monitoring systems, including RS232 and RS485. The ports are wired onto the back of the DSE7310. In order to finalize communication the program will need to be adjusted using the free DSE configuration software to enable the commutation. Contact Winco service for a list of register values.

INSTALLING THE BATTERY

CAUTION

In the following battery installation procedure, check to be sure the DSE7310 is in the "stop" position. This should be your last step before initial start-up.

A customer supplied Group 24/350 CCA battery is required to complete the installation. Installation of the highest CCA rated battery, within the correct BCI group, will increase cold weather starting performance.

BATTERY REQUIREMENTS

Model	Voltage	BCI Group	Min. CCA Rating
DR2014	12	24	650

Installation and servicing of batteries must only be preformed or supervised by personnel knowledgeable of batteries and the required precautions. Keep unauthorized personnel away from batteries.

When installing or replacing batteries, use the proper group/size starting battery. The battery should be a maintenance-free lead acid design. Deep cycle batteries will not work for this application.

CAUTION: PERSONAL DANGER

NEVER dispose a battery in a fire. The battery is capable of exploding.

DO NOT open or mutilate the battery. Released electrolyte is known to be harmful to the skin and eyes and to be very toxic.

These engine-generator sets are all NEGATIVE ground. Be very careful not to connect the battery in reverse polarity, as this may short circuit the battery charging system on the engine.

CAUTION

A battery presents a risk of electrical shock and high short circuit current. The following precautions must be observed when working with batteries:

1. Remove watches, rings, and other metal objects.
2. Use tools with insulated handles.
3. Check both the battery cable ends and the battery posts to be sure they are free of corrosion.
4. Always connect the battery positive cable first and then connect the battery negative cable. When removing the battery cables from the battery, reverse the procedure, disconnect the negative first and then the positive cable.
5. Be sure all connections are tight and coat the terminals and cable ends with dielectric grease.

WARNING

The electrolyte is diluted sulfuric acid that is harmful to the skin and eyes. It is electrically conductive and corrosive. The following precautions must always be taken.

1. Always wear full eye protection and protective clothing.
2. Where electrolyte contacts skin, wash off immediately with water.
3. If electrolyte contacts the eyes, flush thoroughly and immediately with water and seek immediate medical attention
4. Spilled electrolyte is to be washed down with an acid neutralizing agent. A common practice is to use a solution of one pound of bicarbonate of soda (baking soda) to one gallon of water. The bicarbonate of soda solution is to be added until the evidence of reaction (foaming) has ceased. The resulting liquid is to be flushed with water and the area dried.

DANGER: EXPLOSIVE FIRE RISK

1. Never smoke when near batteries.
2. Do not cause a flame or spark in the battery area.
3. Always discharge static electricity from your body before touching batteries by first touching a ground metal surface.

SERVICING BATTERIES

Batteries used on these units may, over time, lose water. This is especially true if you are using a trickle charger to maintain your battery. Different types of batteries require various types of maintenance. Refer to the battery manufacturer for specific recommendations.

NOTE: Always make sure that a new battery is fully charged before installing it on a generator set. Failure to do so can cause damage to the engine control module in the generator set.

All connections must be clean and tight. Depending on your battery type, check the electrolyte in the battery periodically to be sure it is above the plates. Never allow the battery to remain in a discharged condition.

BATTERY CHARGER & BLOCK HEATER

BATTERY CHARGER

A three-stage, on-board marine battery charger is provided standard on this unit. The charger is a 5 amp dual use maintainer and charger designed to keep your batteries fully charged by maintaining them automatically.

Make sure all DC battery connections are tight and clean. Follow battery manufacturer's recommendations.

This charger is mounted under the customer connection on the control side of the generator. The charger will need to be plugged to a customer's power source, using a customer supplied heavy duty, UL approved extension cord. The receptacle is to be powered by a GFCI circuit and installed in accordance to the US National Electric Code. It is suggested that this circuit be fused to 20 Amps.

Low/Charge Mode:

The illuminated blue power LED and red low/charging LED. This indicates the Low/Charge mode is in process. When completed the RED Low/Charge LED will turn off.

Auto Maintain Mode:

The illuminated Green auto maintain LED. This indicates your 12 volt battery is fully charged. During short or long term storage periods, Auto Maintain (Energy Saver) mode will monitor and auto maintain a battery only when needed to maintain a full state of charge. This feature significantly reduces AC Power consumption, lowers operating costs and maximizes reserve power performance.

BLOCK HEATER

The block heater on this unit is a 1000 watt heater and can use the same 20 Amp GFCI fused circuit. The circuit will terminate on the 120 Volt terminal block mount in the customer connection cabinet. The engine block heater installed on this unit should also be plugged into this receptacle. The block heater is thermostatically controlled when plugged in will maintain the engine coolant temperature between 100 and 120 degrees F.

STARTING PROCEDURE

CAUTION

For the first 10 seconds of operation all of the oil, coolant, and electrical shutdowns are disabled. This is enough time to cause catastrophic damage to the equipment if the pre-start checklist is not properly completed and proper maintenance isn't consistently followed.

NOTE: Cold start capabilities are strongly correlated with the quality of the diesel.

LUBRICATION

Before starting the engine, check the oil level in the crankcase. If it is low, refill to the full mark with the proper weight/grade of oil as recommended by the engine manufacturer's maintenance instructions. The necessity of using the correct oil, and keeping the crankcase full, cannot be over emphasized. Failure to use the proper oil and keep the crankcase properly filled will cause excessive engine wear and shorten its useful life.

WINCO recommends our 5W-30 fully synthetic heavy duty engine oil to give you maximum cold weather protection while maintaining excellent performance in warmer weather. We have partnered with a national lubrication oil manufacturer to give you access to Winco private branded premium oil available at comparable prices to conventional oils. See your dealer for additional information.

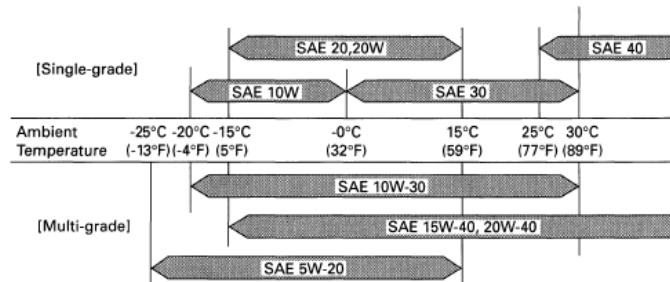

Qty of oil	SAE Grade	Base Stock	International specifications	Sulfur Content In The Fuel
WINCO Broad Range	5W-30	Synthetic	API CJ-4 ACEA E6/E9	< 15 ppm
Premium	10W-40	Semi-Synthetic	API CJ-4 ACEA E6/E9	< 15 ppm
Not Authorized	Monograde			

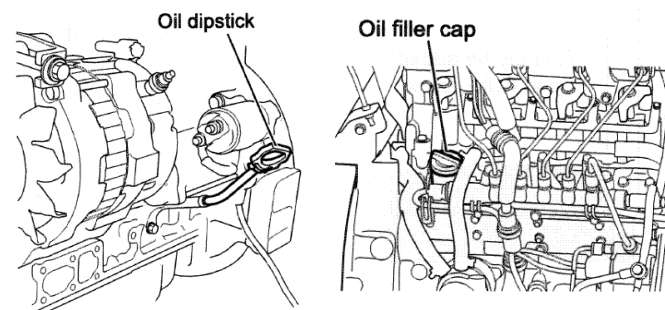

CAUTION: PERSONAL INJURY

Only check oil when the engine is not running and is at a low temperature in order to avoid the risk of burns.

1. Remove the dipstick and ensure the oil level is between the Min and Max limits.
2. If it is difficult to read the level of the oil, clean the dipstick using a clean cloth and then put it back into its seat. Remove the dipstick again and check the level.
3. If level is low, unscrew the cap and refill with suitable oil using the previous table.

COOLANT

Before starting the engine, check the coolant level in the radiator. If it is low, refer to Refilling Coolant in the Maintenance section of this manual. The radiator should be filled to about 1 inch below the filler neck. For additional information on engine coolant requirements, see engine manufacturer's maintenance instructions.

CAUTION

Both too high and too low of coolant temperature can cause an engine malfunction. While the engine is running, ensure the coolant temperature is within appropriate temperature (167 - 194°F).

PRE-START CHECK LIST

There is a Pre-Start & Warranty Form that must be filled out by an Authorized WINCO Service Center. After completing the checklist, the engine-generator set is ready for initial start-up.

WARNING: EQUIPMENT DAMAGE

Before attempting to start this unit, complete your pre-start checklist and ensure the generator mainline circuit breaker (if installed) is in the proper position prior to starting. Starting this unit without it properly connected can cause serious personal injury or equipment damage. DO NOT jump start these engine-generator sets. Starting these units on a low battery or jump starting them will cause damage to the engine control module.

CONTROL LAYOUT

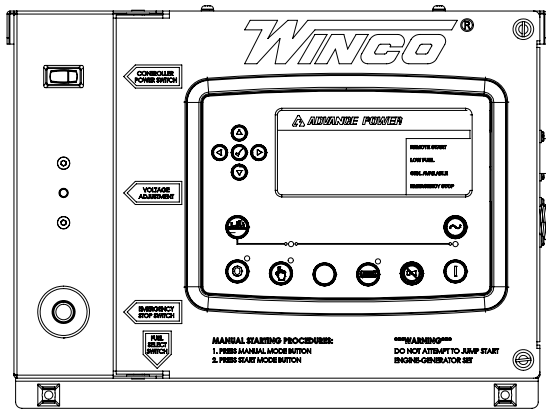

	STOP/RESET - This button places the module into its Stop/Reset mode. This will clear any alarm conditions for which the triggering criteria have been removed. The fuel supply de-energizes and the engine comes to a standstill. Should a remote start signal be present while operating in this mode, a remote start WILL NOT occur.
	MANUAL MODE - This button places the module into its Manual Mode. Once in Manual Mode, the model responds to the Start button to start the generator and run it off load.
	START - Pressing this button from STOP/RESET will start the engine and run the load.
	AUTO MODE - This button places the module into its Auto Mode. This mode allows the module to control the function of the generator automatically.
	ALARM/LAMP TEST - This button silences the audible alarm in the controller, de-activates the Audible Alarm output (if configured) and illuminates all of the LEDs on the module's face as a lamp test function.
	MENU NAVIGATION - Used for navigating the instrumentation, event log, and configuration screens.
	A small rocker switch is located on the underside of the engine control cabinet. On gaseous models, the engine timing is controlled by the ECU on the engine and you need to tell it what fuel you want to operate on; LP or NG. On diesel models, this switch has been disconnected and will do nothing.

PROTECTIONS

When an alarm is present, the common alarm LED if configured will illuminate. The LCD display will show an icon to indicate the failure.

WARNINGS

Warnings are non-critical alarm conditions and do not affect the operation of the generator system, they serve to draw the operator's attention to an undesirable condition. Warning alarms are self-resetting when the fault condition is removed. The icon will appear steady in the display.

SHUTDOWN

Shutdowns are critical alarm conditions that stop the engine and draw the operator's attention to an undesirable condition. Shutdown alarms are latching. The fault must be removed and the STOP/RESET button pressed to reset the module. The icon will be flashing in the display.

MANUAL MODE

1. Press and release the MANUAL MODE button. The small LED light next to it should come on.

Note: There is no start delay in this mode of operation.

2. Press and release the green START ENGINE button. The DSE7310 will send two signals to the engine. The first signal wire #21 will engage the fuel solenoid, the second wire, #22, will engage the starter on the engine. At this point the DSE7310 will start the cranking cycle (10 seconds on and 10 seconds off).

Note: Wire #93 is energized to turn on the glow plugs for 15 seconds first and then the starter and fuel solenoid are engaged.

If the engine fails to start during this cranking period, the starter motor is disengaged and goes into a rest mode after which a second attempt is made to start the engine. Should this sequence continue through 3 cranking cycles the start sequence will be stopped and the display will show "FAILED TO START".

3. During manual operation, the load will not normally be applied to the generator. But caution must be used, if the line power should fail or be turned off the transfer switch during manual operation the load may be applied to the generator.

With the engine running smoothly check the no load voltage and frequency on the digital display. The voltage should be 208/240/480 AC depending on which model you have and a frequency of 59.5 to 60.5 hertz (Hz).

If you have the proper voltage at the generator the next step is to check the voltage at the generator terminals in the Automatic Transfer Switch. The voltage between the G1 and the G3 terminals should be the same as it was on the generator front panel. The voltage should also be checked between the hot terminals (G1 and G3) and the G-N to be certain of a balanced voltage output and a solid neutral connection. The voltage between G1 and G-N should be about 120 volts AC (277 on 480 units). The same approximate voltage should be found between terminals G3 and G-N (120 volts AC).

On three phase panels the G2 voltage level should also be checked. ON 240 VOLT (DELTA) SYSTEMS BE SURE YOU KNOW WHERE THE HIGH VOLTAGE "WILD" LEG IS. IT MUST BE IN THE SAME LOCATION ON THE LINE SIDE AS IT IS ON THE GENERATOR SIDE.
(i.e. if it's on L-3 on the line side it must be on G-3 on the generator side.)

Also on three phase systems make sure that the rotation is the same on the generator as it is on your line power. Failure to insure proper rotation will cause three phase motors to spin backwards possibly damaging them.

NOTICE

If for any reason during the check out procedure the voltage and frequency are not correct, depress the STOP/RESET button and correct the trouble before proceeding.

4. Stopping - There are two ways to stop the unit when it is in the manual mode. Pressing the STOP/RESET button will stop the unit immediately. Pressing the AUTO mode button will stop the unit but only after the cool down timers have timed out and there is no remote start signal being sent to the unit.

AUTO MODE

To activate the automatic start mode you will just need to depress the AUTO button, the LED indicator beside the button confirms that the unit is in automatic mode.

To test the Automatic Transfer Switch, follow the instruction on the operator's manual that came with the transfer switch. If you get a fault during the initial start up or prior to start up, it is most likely a false warning light. Simply reset the ATS to start over.

Once you have completed testing of the ATS, be sure you ALWAYS leave the system in the standby mode, unless servicing the unit. For standby operation, press the AUTO button on the front of the control. The green light should light up next to the AUTO button.

NOTE: For setting the exerciser circuit, for all ATS, see the operator's manual shipped with the ATS.

CONTROL POWER

The DSE7310 controller consumes small amounts of battery power when it is in use. The controller comes with a power switch that disconnects battery power when it is not in use. The switch is designed with a safety relay that prevents it from removing power to the controller while the generator is operating. If the switch is turned off while the engine is running it will continue operating until the engine shuts down and then the controller will power down.

This switch should be used when the generator is not going to be used over the course of several days and the generator is not connected to a battery charger.

A solar charger kit is the easiest way to always maintain the battery during storage in mobile applications. The supplied battery charger can be plugged in to an extension cord on mobile applications.

OPERATING CONDITIONS

NORMAL OPERATION

This generator-engine set needs load and should not idle for long periods of time.

If the generator application is for emergency standby the generator should be exercised at least monthly ideally under load. Load banking the generator at least annually will help keep the engine in good condition.

HARSH ENVIRONMENTS OPERATIONS

Some applications require the generator to operate in harsh environments. One of the most common hazards are extremely dusty conditions. In harsh conditions it is often necessary to take additional steps to keep the equipment clean and operating at its peak. Maintenance intervals on lubricant and filter changes may need to be shortened. An oil quality testing program can also provide early warnings or oil degradation. Efforts may need to be made to reduce the amount of dust and debris entering the housing and generator components.

COLD WEATHER OPERATIONS

The minimum starting temperature with block heater is -13°F.

The degree of fluidity of the engine oil may be reduced at low temperatures due to the separation of the paraffin. This results in the filters becoming clogged.

Oil companies must respect these standards, which provide for the distribution of fuels adapted to the climatic and geographical conditions in various countries.

This generator-engine set needs load and should not idle for long periods of time.

If the generator set will be run in extremely cold environments it may be beneficial to provide means to reduce air circulation to increase the temperature of the enclosure.

Inspect the hoses regularly during cold operation looking for signs of freezing. If the line freezes it will cause pressure to build in the crankcase and may cause an engine seal failure. If the engine operates below optimal temperatures for long periods of time damage may occur.

MAINTENANCE

CHANGING THE OIL

CAUTION: PERSONAL INJURY

Only change oil when the engine is not running and is at a low temperature in order to avoid the risk of burns.

WINCO recommends our 5W-30 fully synthetic heavy duty engine oil to give you maximum cold weather protection while maintaining excellent performance in warmer weather. We have partnered with a national lubrication oil manufacturer to give you access to Winco private branded premium oil available at comparable prices to conventional oils. See your dealer for additional information.

[Ambient temperature]	-30°C (-22°F)	-15°C (5°F)	30°C (86°F)
[Multi grade]	SAE 10W-30		
	SAE 10W-40		
	SAE 15W-40		

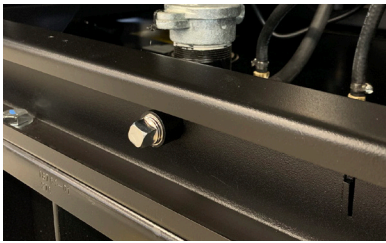

- Remove the dip stick and remove the engine lubricant oil filter plug.
- Drain the oil by removing the plug from the oil sump.
- Once the sump has fully drained, close the valve.
- Top-off through the filler cap using lubricant oil with the suitable oil table in the LUBRICATION section of this manual.

Oil filler cap

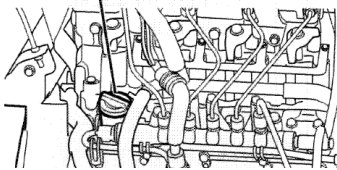

- Use the dip stick to ensure the level of oil does not exceed the "MAX" limit.
- Insert the dipstick and close the lubricant filler cap.
- Dispose of oil in accordance to local codes. DO NOT dispose or allow oil to seep into the ground or sewer systems, doing so will cause environmental damage.

CHANGING OIL FILTER

The filter must be replaced when the lubricant oil is changed.

Only use filters with a filtering degree equal to the original filter.

CAUTION: PERSONAL INJURY

Only change oil when the engine is not running and is at a low temperature in order to avoid the risk of burns.

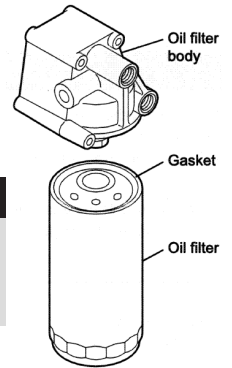

- Use an oil filter wrench to unscrew and remove the oil filter from the filter body and recover the gasket
- Replace the oil filter and gasket.
- Carefully clean the surfaces of the support that are in contact of the gasket.
- Moisten the gasket with a thin layer of oil and place it in its seat on the oil filter.
- Manually tighten the new oil filter on the mount until it is fit up against the gasket.
- Using the oil filter wrench, further tighten the oil filter.

CHANGING COOLANT

Usage Region	Outside Temperature	Long-Life Coolant Concentration
Warm region	10°F or above	30%
Cold Region	-22°F - 10°F	50%

CAUTION: PERSONAL INJURY

Only proceed when the engine is not running and is at a low temperature in order to avoid the risk of burns.

- Remove the cap on the radiator.
- Open the coolant drain cock on the radiator to discharge the coolant.
- Loosen the water drain plug located on the left side of the cylinder block. Discharge the coolant inside the engine.

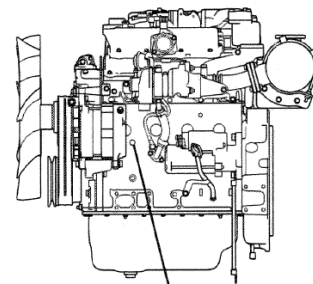

Water drain plug

4. Close the drain cock and the water drain plug. Refill radiator with coolant.

REFILLING COOLANT

1. Remove radiator cap. **Slowly** add coolant to the filler opening.
2. Loosen the air bleeder plug of the EGR cooler to remove any air from the coolant.
3. Tighten the air bleeder plug when the coolant overflows.
4. Firmly close the radiator cap.
5. Fill the reserve tank up to the specified level, close the reserve tank cap.

CHANGING AIR FILTER

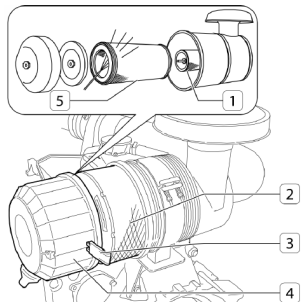

Do NOT remove filter while engine is running.

1. Remove the air filter cover (4) after having released the two quick closing hooks (3).
2. Remove the filter (5). During this operation, take care to ensure that no dust enters the sleeve.
3. Position the filter (5) in its seat.
4. Replace the cover (4) of the air filter and lock it in place using the two quick release hooks (3).

CHECKING WATER IN FUEL FILTER

WARNING: EQUIPMENT DAMAGE

Clean the exhaust valve prior to checking the pre-filter to reduce the risk for system contamination.

Do NOT perform while the engine is running.

1. Place a container for collecting liquids under the pre-filter.
2. Unscrew the plug located at the bottom of the filter.
3. Drain the fluid until only fuel comes out.
4. Fully hand-tighten the plug.
5. Dispose of liquid in accordance

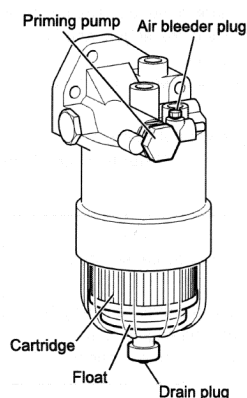

to local codes. DO NOT dispose or allow liquid to seep into the ground or sewer systems, doing so will cause environmental damage.

CLEANING RADIATOR

The surfaces of the radiator come into contact with the outside air and can be subject to deposits and impurities. Clean in accordance to the maintenance schedule with compressed air or steam.

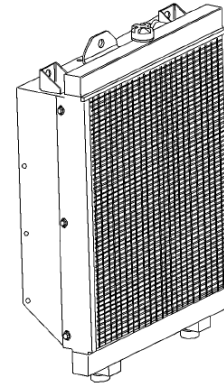

CHANGING THE FUEL FILTER

1. Loosen the drain plug and air bleeder plug to discharge the fuel inside the filter.
2. Using a filter wrench, remove the case.
3. Replace the O-ring of the case and drain plug with the new ones, place the new element in the case. Thinly apply fuel on the O-Ring and screw in the element.
4. Remove air from the fuel.

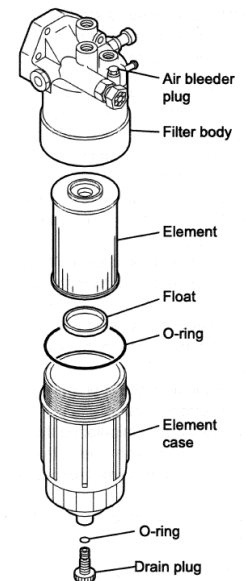

STORAGE

PREPARING THE ENGINE FOR A LONG PERIOD OF INACTIVITY

In the case of a planned period of inactivity that lasts longer than two months, to prevent the interior parts of the engine and some components of the injection system from oxidizing, prepare the engine as follows:

1. Drain the lubricant oil from the sump after heating the engine.
2. Pour 30/M protective oil into the engine up to the "minimum" level indicated on the oil level dipstick. Start the engine and run it for approx. 5 min.

3. Drain the fuel from the injection circuit, from the filter and from the injection pump channels.
4. Connect the fuel circuit to a tank containing CFB protective liquid (ISO 4113) and introduce the liquid by pressurizing the circuit and driving the engine for approx. 2 min. after excluding injection system operation.

The operation required can be completed by directly polarizing terminal 50 of the electric starter motor with positive voltage equal to that of the nominal system voltage, using the designated conductor.

5. Nebulize the 30/M protective oil in a quantity of approx. 130 g (10 g per liter of displacement) in the turbocharger intake inlet, during the engine turning operation described in the previous paragraph.
6. Close all of the engine's intake, discharge, ventilation and bleeding holes with plugs or seal them with adhesive tape.
7. Drain the residual 30/M protective oil from the sump, which can be used for an additional 2 preparations.
8. Place warning notices of ENGINE WITHOUT OIL on the engine and dashboard.

NOTE: When storing in cold regions, make sure the coolant and engine oil are in conditions suitable to the environment. Also, when starting the engine after it has been stored, make sure that there is no snow or foreign matter that could interfere with engine startup, and rotating parts are not frozen.

MAINTENANCE SCHEDULE

Checks In Period of Use	Frequency
Check for water in the fuel filter	Daily
Check Air-Restriction Indicator on Filter	Daily
Engine Oil Level	Daily/Prior to Use
Engine Coolant Level	Daily/Prior to Use
Planned Maintenance	Frequency
Tension and Condition Check of Ancillary Belt	500 Hours
Engine Oil Replacement	250 Hours
Oil Filter Replacement	500 Hours
Fuel Filter Replacement	500 Hours
Clean Radiator	500 Hours
Air Filter Replacement	1250 Hours
Extraordinary Maintenance	Frequency
Ancillary Belt Replacement	3000 Hours
Turbocharger Visual Inspection	1500 Hours
Alternator Visual Inspection	3000 Hours
Clean/Replace Radiator Cap	3000 Hours
Engine Coolant Replacement	3000 Hours

NOTE: Some operating conditions may require more frequent maintenance intervals.

TROUBLESHOOTING TABLE

Problem	Possible Causes
Unit will not crank when power fails	Digital genset not in AUTO Transfer control switch not in AUTOMATIC position Incorrect wiring between ATS and genset Defective control relay in ATS Fuse(s) blown in the DSE7310 Defective DSE7310 Loose or dirty battery terminals Defective starter Defective start solenoid Low/dead battery
Engine won't crank	Low/dead battery Blown DC fuses Defective DSE7310 Defective key switch Loose or dirty battery terminals Defective starter Defective start solenoid Locked up engine genset Defective engine harness Improper battery voltage to start solenoid, fuel pump, or fuel solenoid
Engine cranks but will not start	Improper fuel delivery to the unit Fuel supply shut off Fuel tank empty Air in the fuel system Engine fuel solenoid has not opened Defective fuel pump Defective fuel solenoid Defective engine harness Improper battery voltage to fuel pump or fuel solenoid
Engine starts, then stops and alarm light comes on	Engine oil pressure is low Engine has high water temperature Engine has overspeed Engine has gone into overcrank No output from AC generator Loss of speed signal Loss of run signal
Engine will not come up to speed after it starts	Insufficient fuel volume getting to the unit 1. Too small of fuel line 2. Fuel racks not open properly Governor is defective AC short in generator components
ATS will not transfer to Emergency Supply (generator)	No AC generator output Defective ATS control board. See ATS manual Circuit breaker open or defective
ATS will not re-transfer to normal power	Proper power line not available at line terminals in ATS panel Defective ATS control board. See ATS manual
No AC output from generator	Defective diode Defective voltage regulator Defective rotor Defective stator Defective exciter rotor Defective exciter stator AC short in the output leads Defective/open generator output breaker Wiring error

WIRING SIZE TABLE

The table below is based on Table 310.15 (B) (16) in the National Electric Code 2014 edition. Allowable ampacities of insulated conductors rated 0 through 2000V, 75°C through 90°C. Not more than three current-carrying conductors in Raceway, Cable, or Earth (direct buried). Adjust for 40°C (104°F) ambient temperature.

Copper 75°C	Copper 90°C		Aluminum Copper Clad Aluminum 75°C	Aluminum Copper Clad Aluminum 90°C
Wire Type: RHW, THHW, THW, THWN, XHHW, USE, ZW	Wire Type: TBS, SA, SIS, FEP, FEPB, MI, RHH, RHW-2, THHN, THHW, THW-2, XHH, XHHW, XHHW-2, ZW-2	SIZE AWG OR KCMIL	Wire Type: RHW, THHW, THW, THWN, XHHW, USE	Wire Type: TBS, SA, SIS, THHN, THW-2, THWN-2, RHH, RHW-2, USE- 2, XHH, XHHW, XHHW-2, ZW-2
44	50	8	35	41
57	68	6	44	55
75	86	4	57	68
88	100	3	66	77
101	118	2	79	91
114	137	1	88	105
132	155	1/0	106	123
154	177	2/0	119	137
176	205	3/0	136	159
202	237	4/0	158	187
224	264	250	180	209
251	291	300	202	232
273	319	350	220	255
295	346	400	238	278
334	391	500	273	319
370	432	600	299	350
405	473	700	330	382
418	487	750	339	396
431	505	800	348	410
458	532	900	374	437
480	560	1000	392	455
519	605	1250	427	496
550	642	1500	458	532
572	669	1750	480	560
585	683	2000	493	573

For additional information, see table 310.15 of the National Electric Code.

ENGINE HARNESS SCHEMATIC

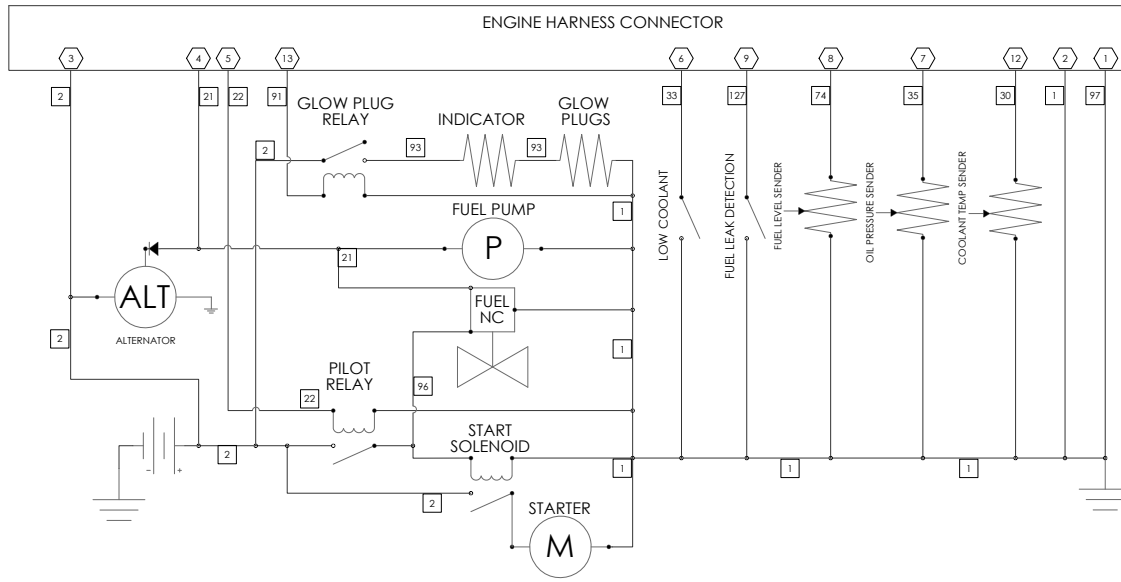

NOTE:
 SOME MODELS COME
 EQUIPED WITH FUEL
 LEVEL, OIL PRESSURE
 AND COOLANT
 TEMPERATURE SWITCHES.
 SENDER UNITS PICTURED.
 FUEL AND LOW
 COOLANT MONITORING
 FEATURES ARE
 OPTIONAL.

DSE7310 WIRING DIAGRAM

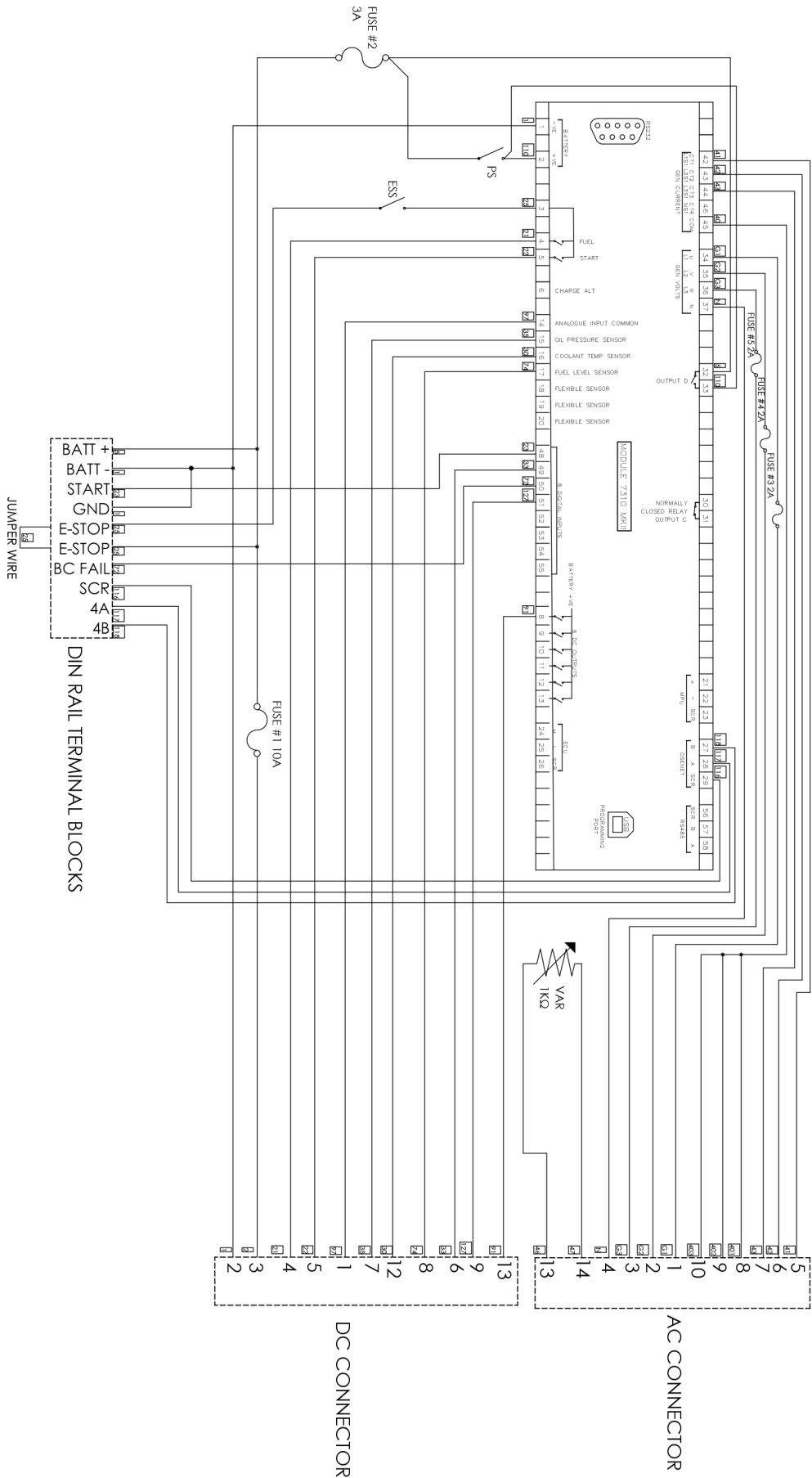

WIRING DIAGRAMS

THREE PHASE - HIGH WYE 277/480V

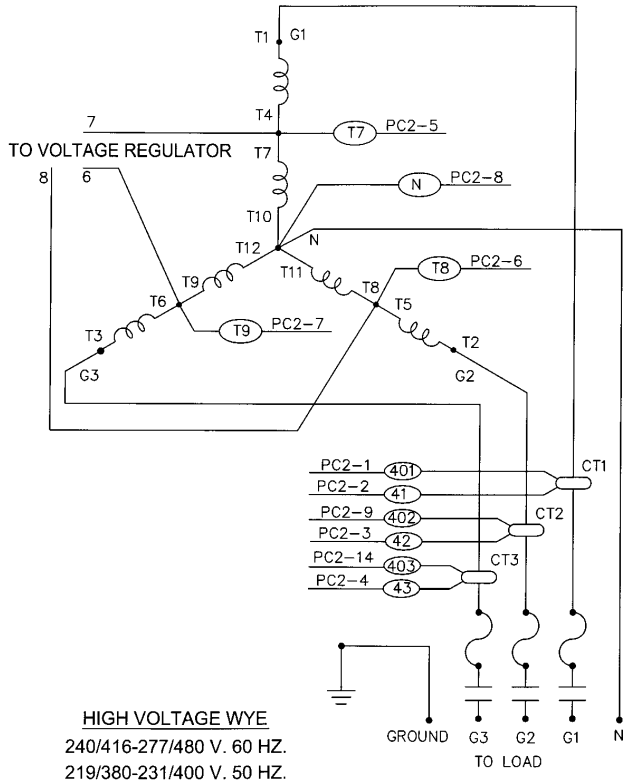

THREE PHASE - LOW WYE 120/208V

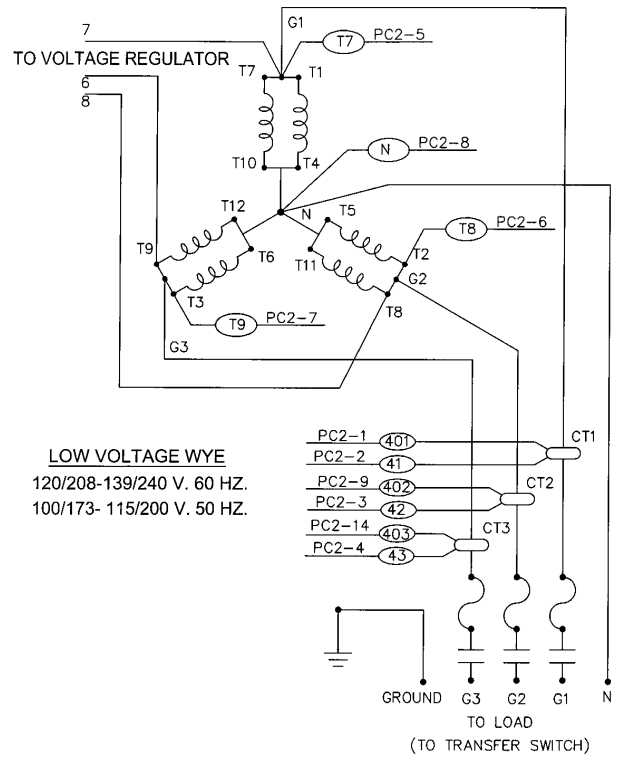

SINGLE PHASE 120/240V

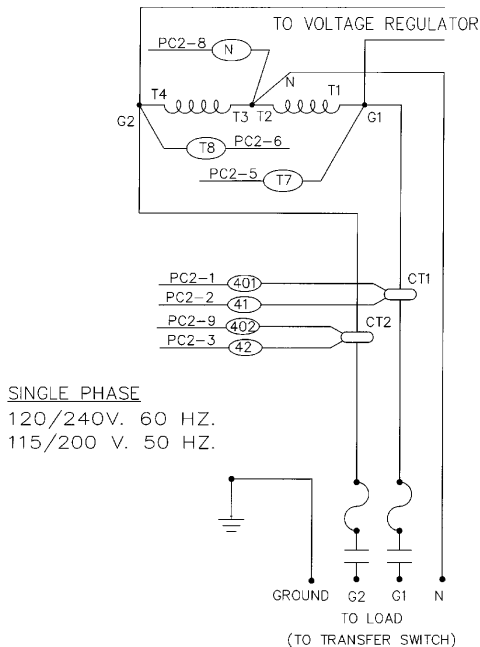

THREE PHASE DELTA 120/240V

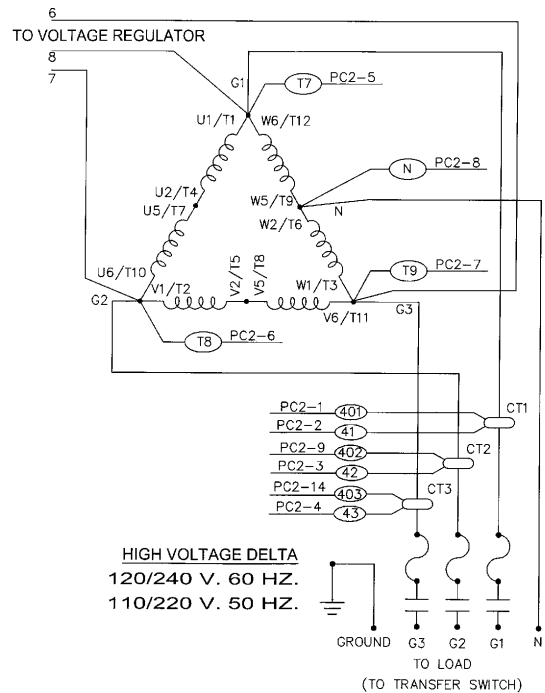

WINCO Inc. has been engineering and manufacturing high quality generators since 1927. WINCO Inc. warrants to the original owner that the purchased product is free from defects in materials and/or workmanship for the period of time outlined below. If the product should prove defective within the time period outlined below, it will be repaired, adjusted or replaced at the option of WINCO Inc., provided that the product, upon inspection by an authorized WINCO Inc. service center, has been found to have been properly installed, maintained and operated in accordance with WINCO Inc.'s Installation and Operating Manuals, engine manufacturer installation and operation guidelines, and National and local code. This limited warranty is not valid or enforceable unless:

1. All supporting product maintenance records are kept on file and made available upon request from WINCO Inc.
2. A copy of the WINCO Inc. Start-up Completion and Warranty Validation Checklist is properly and completely filled out and returned to WINCO Inc. within 30 days of start-up.
3. The product is routinely exercised in accordance with operating instructions. This warranty does not apply to malfunctions caused by physical damage, misuse, improper installation, repair or service by unauthorized persons; or normal wear and tear. The warranty is not assignable.

Standby WINCO Inc. Product Warranty Period:

- Engine generator set: Parts and Labor for one (2) year from the date of factory invoice or 2,000 hours (whichever occurs first).
- Accessories (installed on the product or shipped loose): Parts and Labor for one (1) year from the date of factory invoice or 2,000 hours (whichever occurs first).

The start of the warranty period can be adjusted to the date of unit start-up (limited up to 180 days from invoice date) provided that the following information is provided to WINCO Inc. at the time of start-up:

1. A copy of the WINCO Inc. Start-up Completion and Warranty Validation Checklist is properly and completely filled out and returned to WINCO Inc. within 30 days of start-up.
2. Some engines may require revalidation after long-term storage. The engine revalidation process if included in the manual must be followed.

To obtain warranty service:

Contact your nearest authorized WINCO Inc. service center. For assistance in locating your nearest authorized service center, contact WINCO Inc.'s Service Department.

Warranty service may be performed by an authorized WINCO Inc. service center only. Service work performed by unauthorized persons will void all warranties.

WINCO Inc. shall not be liable for any claim in an amount greater than the purchase price of the product. In no event shall WINCO Inc. be held liable for any special, indirect, consequential or liquidated damages.

WINCO Inc. shall not be liable for any claim that requires replacement of engine, part, or component of the product that is no longer manufactured or available. Additionally, WINCO Inc. will not be liable for any engine replacement that may require an emissions tier-level change.

THERE ARE NO EXPRESS WARRANTIES OTHER THAN THOSE DESCRIBED HEREIN. THERE ARE NO OTHER WARRANTIES, EXPRESSED OR IMPLIED, OR OTHERWISE CREATED UNDER THE UNIFORM COMMERCIAL CODE, INCLUDING BUT NOT LIMITED TO WARRANTIES OF MERCHANTABILITY, OR WARRANTIES OF FITNESS FOR A PARTICULAR PURPOSE.

The following items and/or circumstances are excluded from this limited warranty:

- Engine starting batteries: The battery manufacturers' warranty applies. Consult your local battery supplier for warranty service.
- Fuel system and/or governing system adjustments performed during or after start-up.
- Normal maintenance items: Consumable items such as belts, filters and hoses.
- Damage caused by over-loading the generator and failure to adequately provide over-load protection.
- LP/NG fuel adjustments or conversion from one fuel to another.
- Any repeat or shop come-back repairs resulting from poor service work or improper diagnosis and testing. Replacement of parts as a trial-and-error method of diagnosis will not be considered for warranty.
- Adjustments and tune-ups performed during start-up or thereafter.
- Loose connections (electrical and mechanical) not found during start-up.
- All fluid level related items including low coolant not found during start-up or checked during regular maintenance intervals.
- Equipment modifications made without the written consent of WINCO Inc. will void all warranties.
- Shipping damage of any type. All equipment is shipped F.O.B. factory and risk of loss transfers to the carrier once loaded for shipment. It is the responsibility of the receiving party to sign for the receipt of, and note any shipping damage to the equipment. Freight damage claim filing is the responsibility of the receiving party. In the rare event that damage occurs during shipment, WINCO Inc. will not warrant any damage to the unit resulting from packaging material.
- Any special access fees, requirements or after hours scheduling to gain access to the equipment for warranty service purposes.
- Rental generators used while warranty work is being performed.
- Damages caused by acts of nature, such as lightning, wind, flood, wild fires, or earthquake.
- Any damage due to situations beyond the control of the manufacturing and/or workmanship of the product.
- Use of non-protected steel enclosure within 25 miles of the coast.
- Damage caused by improper installation or failure to provide adequate ventilation.
- Misapplication of the equipment such as usage outside the original design parameters as stated on the nameplate of the equipment.
- Equipment purchased at the standby rating that is being used in a prime power application(s).
- Diesel engine "Wet Stacking" due to lightly loaded diesel engines.
- Travel time or service calls unless given written authorization by WINCO Inc.