

THIS DRAWING AND THE DATA DISCLOSED HEREIN OR HEREWITH IS CONFIDENTIAL AND PROPRIETARY AND IS NOT TO BE REPRODUCED, USED, OR DISCLOSED IN WHOLE OR IN PART TO ANYONE WITHOUT THE EXPRESSED WRITTEN PERMISSION OF MULTIQUIP COMPANY.

PART LISTS				
ITEM	PART NUMBER	QTY	DESCRIPTION	MANUFACTURE
1	DCA125SSIU4F (TIER 4F)	1	125KVA GENSET 125SSIU4F GENSET WEIGHT (DRY): 5,286bs	MQ POWER
2	TRLR125USE	1	TRAILER (MODEL: TRLR125USE) TRAILER WT. ONLY (APPROX.): 1,693lbs G.V.W.R.: 10,000lbs TONGUE WT.: OVERALL DIMENSION: 181L X 79.5W X 90H	MQ POWER
3	EE44774	4	TIRE ST225/75D15 LR-D 2540lbs RATING WHEEL 15 X 6	TASKMASTER
4	EE56658	2	ELECTRIC TORSION AXLE, 5,000lbs RATING	DEXTER AXLE
5	EE43518	1	JACK, 5K	CEQUENT
6		1	SEE HITCH OPTION TABLE	

HITCH OPTIONS	
3" ADJUSTABLE EYE 20,000lbs (EE36264 - PRIMED)	
2-5/16" BALL COUPLER 14,000lbs (EE43253 - PLATED)	

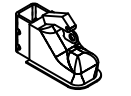
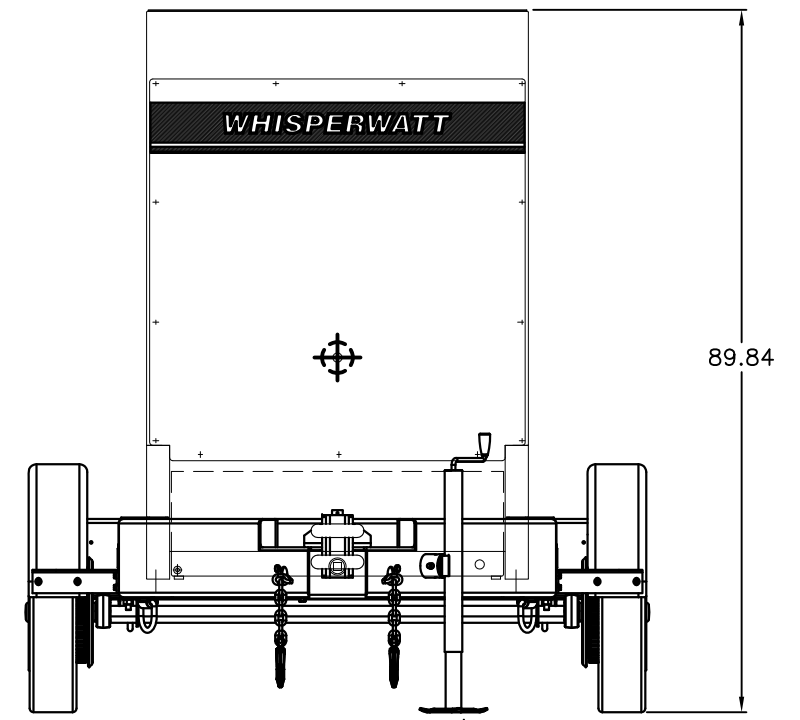
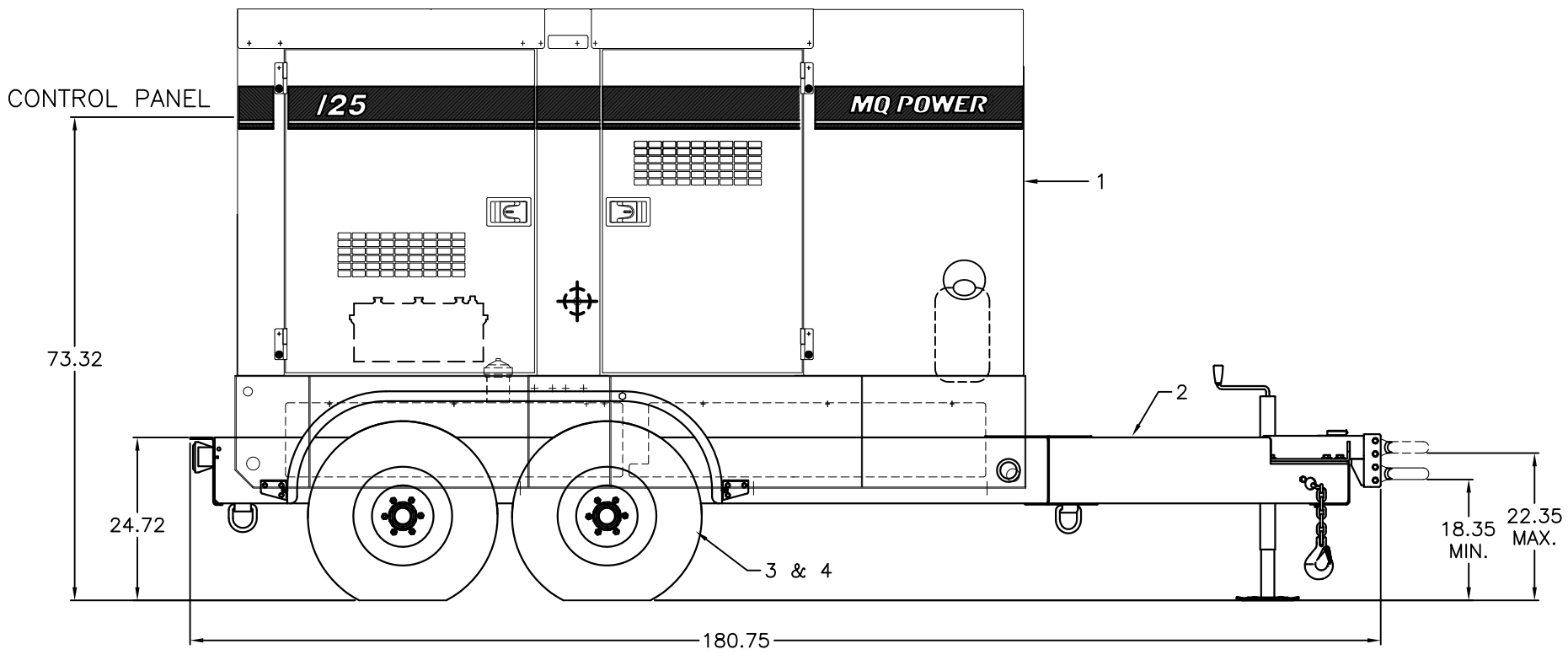
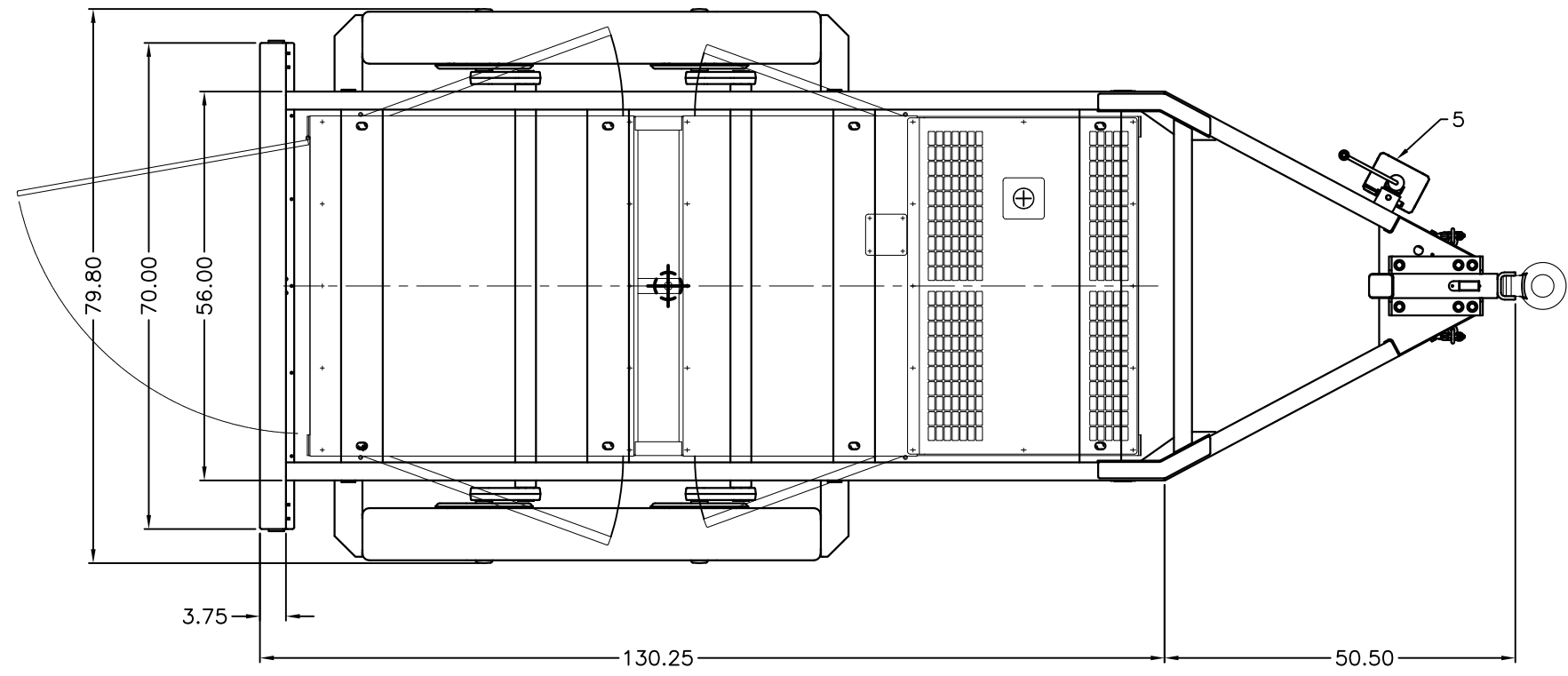

UNLESS OTHERWISE SPECIFIED DIMENSIONS ARE IN INCHES TOLERANCES ARE :		CUSTOMER		MQ POWER TEL: (310) 537-3700/FAX: (310) 632-2656 18910 WILMINGTON AVENUE CARSON, CA 90746		
FRACTIONS	DECIMALS	ANGLES	JOB NO.			
±	.XX ±	±		APPROVALS		DATE
	.XXX ±			DRAWN		
DERIVED FROM		MATERIAL		J. TRAN		06/12/15
REV	DATE	FINISH		CHECKED		
CAD CODE 202095		DO NOT SCALE DRAWING		SALESMAN		
			DCA125SSIU4F GENSET		MTD ON TRLR125US ELEC. TRAILER	
SIZE	FSCM NO.	DWG. NO.		SHEET		
D		202095		1 / 1		
SCALE			1/12			

DWG. NO. 202095