



DCA125SSIU4F

Generator

WhisperWatt™

Prime Rating — 100kW (125kVA)

Standby Rating — 110kW (137.5kVA)

3-Phase, 60 Hertz, 0.8 PF

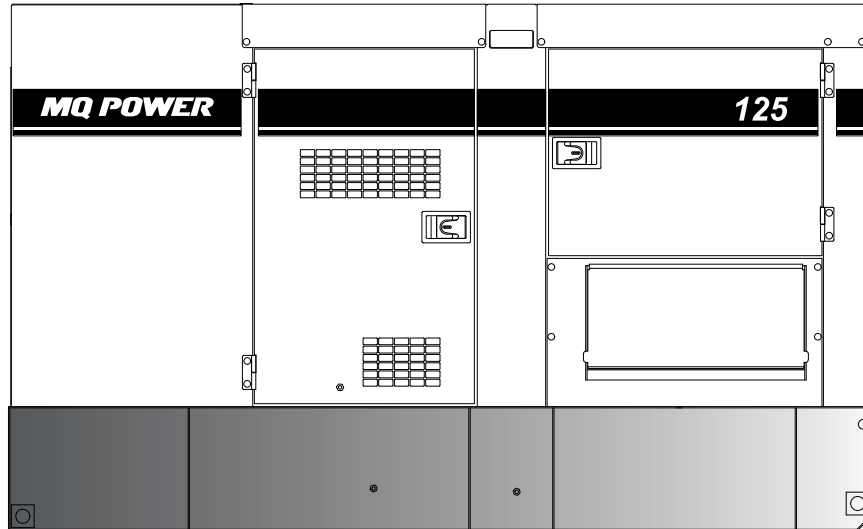

STANDARD FEATURES

- Heavy duty, 4-cycle, direct injection, heated crankcase vent, turbocharged, charge air cooled, 1000W block heater, diesel engine provides maximum reliability.
- EPA emissions certified - Tier 4 Final emissions compliant.
- Microprocessor engine control system maintains frequency to $\pm 0.25\%$.
- Full load acceptance of standby nameplate rating in a single step.
- Fuel/water separator removes condensation from fuel for extended engine life. Panel mounted alarm light included.
- Sound attenuated, weather resistant, steel housing provides operation at 66 dB(A) at 23 feet. Fully lockable enclosure allows safe unattended operation.
- E-coat and powder coat paint provides durability and weather protection.
- Internal fuel tank with direct reading fuel gauge.
- Spill Containment - Bunded design protects environment by capturing up to 128% of engine fluids.
- Brushless alternator reduces service and maintenance requirements and meets temperature rise standards for Class F insulation systems.
 - Open delta alternator design provides virtually unlimited excitation for maximum motor starting capability.
 - Automatic voltage regulator (AVR) provides precise regulation.
- Fully covered power panel. Three-phase terminals and single phase receptacles allow fast and convenient hookup for most applications including temporary power boxes, tools and lighting equipment. All are NEMA standard.
- ECU845 microprocessor-based digital generator controller.
 - Remote 2-wire start/stop control.
 - High visibility LCD display with heated screen and alphanumeric readout.
 - Operational temperature range of -40° to 85° C.
 - AC monitoring along with fuel and DEF level indicators.
- Digital engine gauges including oil pressure, water temperature, battery volts, engine speed, engine load, fuel level and DEF level.
- Analog generator instrumentation including AC ammeter, AC voltmeter, frequency meter, ammeter phase selector switch, voltmeter phase selector switch, and voltage regulator adjustment potentiometer.
- Automatic safety shutdown system monitors the water temperature, engine oil pressure, low DEF, overspeed and overcrank. Warning lights indicate abnormal conditions.
- Voltage selector switch offers the operator a wide range of voltages that are manually selectable. Fine tuning of the output voltage can be accomplished by adjusting the voltage regulator control knob to obtain the desired voltage.
- Emergency Stop Switch — when manually activated, shuts down generator in the event of an emergency.



DCA125SSIU4F Generator

SPECIFICATIONS

Generator Specifications

Design	Revolving field, self-ventilated Drip-proof, single bearing	
Armature Connection	Star with Neutral	Zig Zag
Phase	3	Single
Standby Output	110KW (137.5 KVA)	79 KW
Prime Output	100 KW (125 KVA)	72 KW
3Ø Voltage (L-L/L-N) Voltage Selector Switch at 3Ø 240/139	208Y/120, 220Y/127, 240Y/139	N/A
3Ø Voltage (L-L/L-N) Voltage Selector Switch at 3Ø 480/277	416Y/240, 440Y/254, 480Y/277	N/A
1Ø Voltage (L-L/L-N) Voltage Selector Switch at 1Ø 240/120	N/A	240/120
Power Factor	0.8	1.0
Voltage Regulation (No load to full load)	±0.5%	
Generator RPM	1800	
Frequency	60 Hz	
Winding Pitch	2/3	
No. of Poles	4	
Excitation	Brushless with AVR	
Frequency Regulation: No Load to Full Load	Isochronous under varying loads from no load to 100% rated load	
Frequency Regulation: Steady State	±0.25% of mean value for constant loads from no load to full load.	
Insulation	Class F	
Sound Level dB(A) Full load at 23 feet	66	

Engine Specifications

Make / Model	Isuzu / BR-4HK1X	
Emissions	EPA Tier 4 Final Certified	
Starting System	Electric	
Design	4-cycle, water cooled, direct injection, turbocharged. Charged Air Cooled EGR, DOC and SCR.	
Displacement	317 in ³ (5193 cc)	
No. cylinders	4	
Bore x Stroke	4.52 x 4.92 in. (115 x 125 mm)	
Gross Engine Power Output	170.8 hp (127.4 kW)	
BMEP	211 psi (1458 kPa)	
Piston Speed	1476 ft/min (7.5 m/s)	
Compression Ratio	16.5:1	
Engine Speed	1800 rpm	
Overspeed Limit	2070 rpm	
Oil Capacity	6.05 gallons (22.9 liters)	
Battery	12V 150Ah x 1	

Fuel System

Recommended Fuel	ASTM-D975-No.1 & No.2-D*	
Maximum Fuel Flow (per hour)	19 gallons (71.9 liters)	
Maximum Inlet Restriction (Hg)	2.9 in (73.6 mm)	
Fuel Tank Capacity	169 gallons (640 liters)	
Fuel Consumption	gph	lph
At full load	7.1	26.9
At 3/4 load	5.6	21.2
At 1/2 load	4.1	15.5
At 1/4 load	2.6	10.0
DEF Tank Capacity	7.4 gallons (28 liters)	

* - Use ultra-low sulfur diesel fuel.

Cooling System

Fan Load	6.57 hp (4.9 kW)
Coolant Capacity (with radiator)	10.3 gallons (39 liters)
Coolant Flow Rate (per minute)	60.8 gallons (230 liters)
Heat Rejection to Coolant (per minute)	4456 Btu (4.7 MJ)
Maximum Coolant Friction Head	1.1 psi (7.7 kPa)
Maximum Coolant Static Head	3.3 feet (1 meter)
Ambient Temperature Rating	104°F (40°C)

Air

Combustion Air	244 cfm (6.9 m ³ /min)
Maximum Air Cleaner Restriction	25 in. H ₂ O (6.25 kPa)
Alternator Cooling Air	1352 cfm (38.3 m ³ /min)
Radiator Cooling Air	6005 cfm (170 m ³ /min)

Exhaust System

Gas Flow (full load)	512 cfm (14.5 m ³ /min)
Gas Temperature	658°F (348°C)
Maximum Back Pressure	100 in. H ₂ O (25 kPa)

Amperage

Rated Voltage	Maximum Amps
1Ø 120 Volt	300A x 2 (Zigzag)
1Ø 240 Volt	300 A (Zigzag)
3Ø 208 Volt	300 Amps
3Ø 240 Volt	300 Amps
3Ø 480 Volt	150 Amps
Main Line Circuit Breaker Rating	300 Amps
Over Current Relay Trip Set Point 480V Mode Only	152 Amps

WARRANTY*

Isuzu Engine**

12 months from date of purchase with unlimited hours or 36 months from date of purchase with 3000 hours (whichever occurs first).

Generator

24 months from date of purchase or 2000 hours (whichever occurs first).

Trailer

12 months excluding normal wear items.

*Refer to the express written, one-year limited warranty sheet for additional information.

**Refer to Isuzu Diesel Engine Limited Warranty for details.

NOTICE

Specifications sheet is subject to change and is not intended for use in installation design.



DCA125SSIU4F

Generator

MQ POWER DECIBEL LEVELS

Our soundproof housing allows substantially lower operating noise levels than competitive designs. WhisperWatts are at home on construction sites, in residential neighborhoods, and at hospitals — just about anywhere.

- 90 — Subway / truck traffic
- 80 — Average city traffic
- 70 — Inside car at 60 mph
- 60 — Air conditioner at 20 feet
- 50 — Normal conversation



GENERATOR OUTPUT PANEL

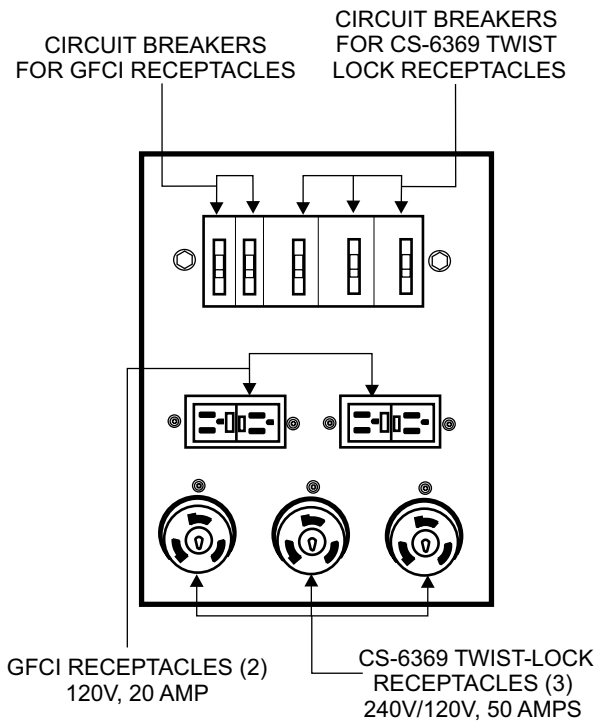

OPTIONAL GENERATOR FEATURES

- **Parallel Controls** — provides the ability to connect multiple generators together into a single power generation system.
- **PowerBalance™** — designed to assist generators when operating under low temperature and/or low load conditions to insure peak performance.
- **Battery Charger** — provides fully automatic and self-adjusting charging to the generator's battery system.
- **Trailer Mounted Package** — meets National Highway Traffic Safety Administration (NHTSA) regulations. Trailer is equipped with electronic or surge brakes with double axle configuration.

OPTIONAL CONTROL FEATURES

- **Audible Alarm** — alerts operator of abnormal conditions.

OPTIONAL FUEL CELL FEATURES

- **Sub-base Fuel Cells (double wall)** — additional fuel cell for extended runtime operation. Contains a leak sensor, low fuel level switch, and a secondary containment tank. UL142 listed.
- 12 hours of minimum run time.
- 24 hours of minimum run time.

OPTIONAL OUTPUT CONNECTIONS

- **Cam-Lok Connectors** — provides quick disconnect alternative to bolt-on connectors.
- **Pin and Sleeve Connectors** — provides industry standard connectors for all voltage requirements.
- **Output Cable** — available in any custom length and size configuration.



DCA125SSIU4F

Generator

SKID-MOUNT DIMENSIONS

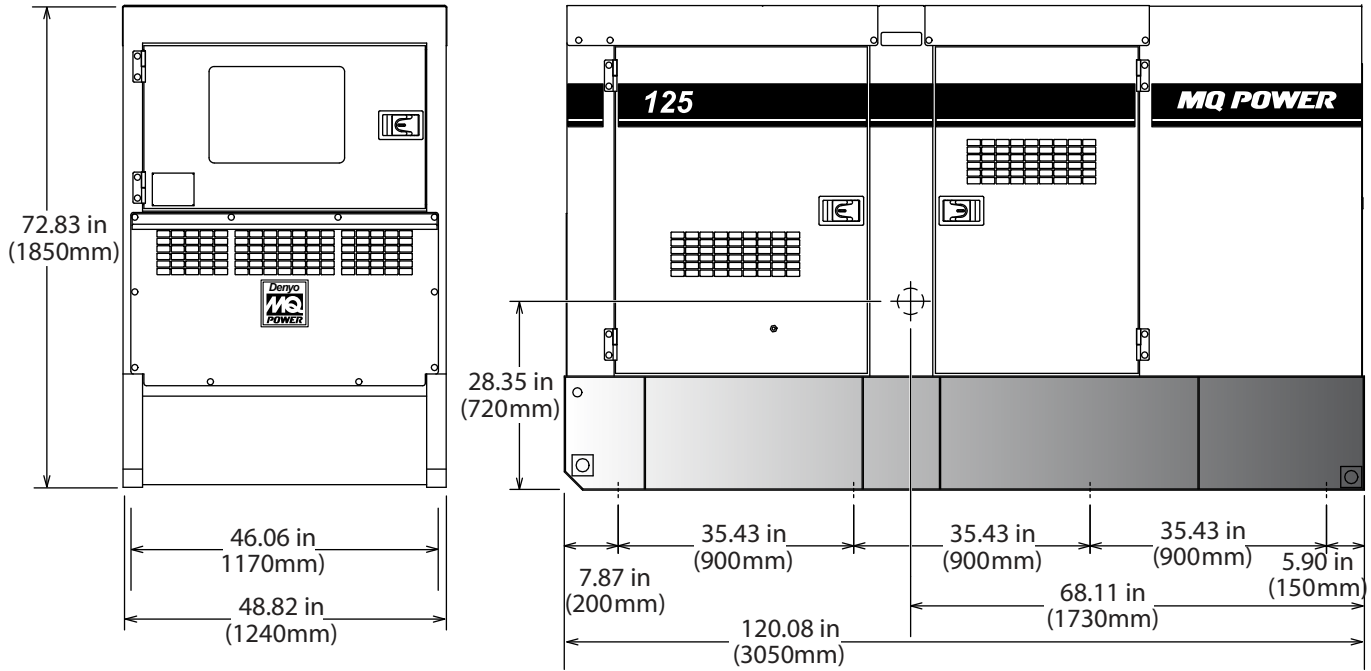

TRAILER-MOUNT DIMENSIONS

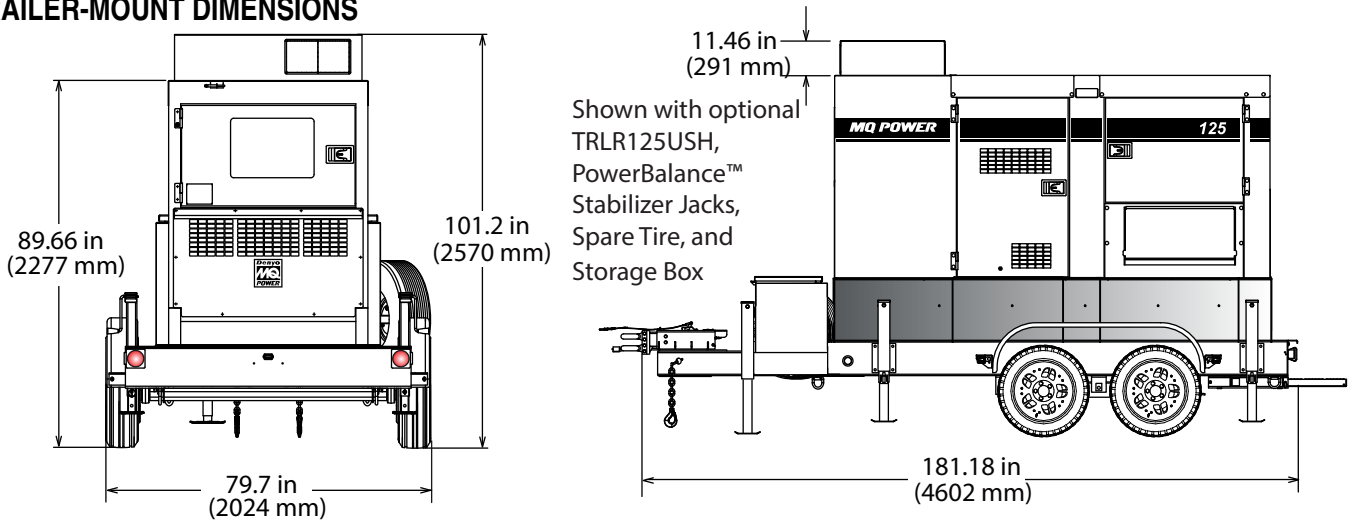

DCA125SSIU4F Weights*

Dry Weight	5,291 lbs. (2,400 kg)
Wet Weight	6,702 lbs. (3,040 kg)
Max. Lifting Point Capacity	14,050 lb. (6,370 kg)

* Weights do not include options.

DCA125SSIU4F and TRLR125US Weights*

Dry Weight (with TRLR125US)	7,013 lbs. (3,181 kg)
Wet Weight (with TRLR125US)	8,424 lbs. (3,821 kg)

Generator can be placed on MQ Trailer Models TRLR125US and TRLR180XF.

NOTICE

Features and Specifications are subject to change without notice.



MULTIQUIP
 6141 Katella Avenue Suite 200
 Cypress, CA 90630
 310-537-3700
 E-MAIL: mq@multiquip.com
 WEBSITE: www.multiquip.com