

MODEL
HDA-100F

100kW/60Hz/1800RPM

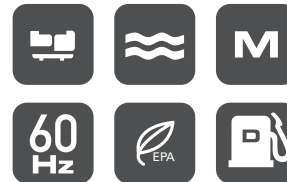

60Hz STANDBY POWER RATINGS

Model	Rating	Phase	Voltage	PF	HZ	KW	KVA	AMPS	SKVA @ 30% Voltage Dip
HDA-100F M6	Standby	1Ph	120/240	1.0	60	100	100	417	290
HDA-100F T6	Standby	3Ph	347/600	0.8	60	100	125	120	345

Description

HIPOWER[®] Heavy Duty Agriculture[™] generators are an efficient, reliable and versatile source of back-up electrical power that have been designed to operate in the most extreme working conditions. All HIPOWER[®] Heavy Duty Agriculture[™] generators combine an innovative design and the use of high quality materials that provide the user with the most dependable power that you can rely on for non-stop power with easy to operate controls. Powered by a radiator-cooled, industrial FPT Diesel engine, which meets current Environmental Protection Agency (EPA) TIER 3 exhaust emission regulations, driving a single bearing, four-pole, three-phase alternator, with IP23 protection. The Standby Power kW rating for generator set is given with a 125 °C alternator winding temperature rise.

HIPOWER[®] Features and Benefits

FPT Diesel Engine: Long-life, heavy-duty, 4-cycle, direct injection engine for economy of operation and maximum reliability and durability. Capable of full rated load acceptance in one step.

Cooling: Radiator with belt driven pusher fan.

Air Filter: Heavy-duty replaceable element air-cleaner.

Alternator: Single bearing, rotating field, self-excited, self-ventilated, 12-wire dedicated, and 4-wire dedicated for single phase version, 60Hz brushless alternator, Class H insulation. Automatic voltage regulator (AVR) providing close voltage regulation and skVA starting capability for electric motor loads.

Certification: ISO 8528-5.

HIPOWER[®] Features and Benefits

Exhaust: Low noise, steel residential-type exhaust silencer.

Fuel Filtration: Standard and secondary water separator with visible level on fuel filters.

Digital Controls: Digital control panel with manual and automatic start and stop features. Many programmable automatic functions for local and remote controls with LED lights, tamper proof engine hour recorder.

Battle Mode: Battle Mode is a generator set mode that prevents the generator from shutting down during critical operation except by a few shutdown faults.

APPLICATION DATA

ENGINE SPECIFICATION

Manufacturer	FPT-Iveco
Model	N67TM1X
EPA certified	Tier 3
Crankshaft speed	1,800 rpm
Type	Diesel, 4-stroke
Injection	Direct
Aspiration	Turbocharged aftercooled air/air
Number of Cylinders	6
Cylinder arrangement	In-line
Displacement CID (liters)	408.9 (6.7)
Bore and Stroke ins (mm)	4.1 x 5.2 (104 x 132)
Nominal power	131.4 hp
Cooling	Liquid
Governor	Mechanical
Governor Regulation Class	ISO 8528 Part 1 Class G3
Frequency Regulation	Mechanical Droop, Less than 5%
Starting motor & alternator	12 volt
Compression ratio	17.5:1
Air cleaner type	Heavy Duty - Single Cartridge
Exhaust gas flow cu. ft./minute (cu.m. /minute)	910 (25.8)
Max. Exhaust temp at full load degrees °F (°C)	896 (480)
Max. permissible back pressure - ins H2O (kPA)	20 (5)

COOLING SYSTEM

Engine cooling air flow - cu. ft./min (cu. m/min)	8,052 (228)
Alternator cooling flow - cu. ft./min (cu. m/min)	1,307 (37)
Total cooling air flow (engine + alternator + combustion) - cu. ft./min (cu. m/min)	9,748 (276)
Total cooling capacity - US gallons (liters)	3.96 (15)
Max. Operating Temperature °F (°C)	122 (50)

LUBRICATION SYSTEM

Oil pan capacity - US gallons (liters)	3.2 (12)
Oil pan capacity with filter - US gallons (liters)	4.5 (17.2)
Oil cooler	Water - cooled
Recommended lubricating oil grade	SAE 10W30 - API (CF, CF-4, CI-4) - refer to owners manual
Oil consumption at full load	0.14% of fuel
Oil pressure – psi (kPA)	72.6 (500)

ENGINE ELECTRICAL SYSTEM

Starting motor voltage	12 volt
Cold Cranking Amps - minimum	650 Amp
Battery charging Alternator	90 Amp
Battery capacity	650 Amps

HIMOINSA POWER SYSTEMS, INC.

16600 S. Theden Street, Olathe, KS 66062

Tel: 913 495 5557 | Fax: 913 495 5575 www.hipowersystems.com

Codes and Standards Compliances used where applicable



APPLICATION DATA

FUEL SYSTEM

Recommended fuel	# 2 - ULSD
Fuel supply line, min. ID mm(in.)	9.5 (3/8")
Fuel return line,min. ID, mm (in.)	9.5 (3/8")
Max. lift, fuel pump, type, m (ft)	TBD
Fuel filter	Secondary 5 Microns @ 98% Efficiency

FUEL COMPSUNTION

	Standby Power Rating
100% load – US gallons/hour (liters/hour)	7.8 (29.5)
75% load - US gallons/hour (liters/hour)	5.7 (21.6)
50% load - US gallons/hour (liters/hour)	2.9 (11)
25% load - US gallons/hour (liters/hour)	1.5 (5.5)

ALTERNATOR SPECIFICATION

Manufacturer	STAMFORD
Model	UCI274C - UCI274C
Voltage	120/240V - 347/600V
Alternator Type	Four pole, rotating field
Excitation System	Brushless.
Power factor	1.0/0.8
Number of leads	4 leads dedicated (Single phase) - 12-leads dedicated (600V)
Stator Pitch	2/3
Insulation	Class H
Windings – Temperature Rise	125/40° C
Enclosure (IEC-34-S)	IP23
Bearing	Single, sealed
Coupling	Flexible disc
Amortisseur windings	Full
Voltage regulation – no load to full load with AS480 AVR	± 1%
TIF	<50
Radio Frequency Emissions compliance	Meets requirements of most industrial and commercial applications
Line harmonics	5% maximum

STANDARD ACCESSORIES

• Radiator with pusher fan	• Junction Load Box
• DSE4510 Control Panel	• Water Jacket Heater
• Battery Switch	• Battery Charger
• Emergency Stop	• Air Filter
• Battle Mode	

OPTIONAL ACCESSORIES

• Battery	• PMG
-----------	-------

HIMOinsa POWER SYSTEMS, INC.

16600 S. Theden Street, Olathe, KS 66062

Tel: 913 495 5557 | Fax: 913 495 5575 www.hipowersystems.com

Codes and Standards Compliances used where applicable



CONTROL SYSTEMS STANDARD FEATURES - Generator Digital Control

DSE4520 MKII[®] Control Panel: Deepsea Auto Mains Failure digital controller with auto and manual start capability. Digital readout for: volts between each phase & neutral, volts between phases, amps per phase, frequency, kW and kVA power, power factor, KW hour with accumulation by day, month and year, fuel reserve, oil pressure, coolant temperature, battery volts and charging alternator volts, engine speed, hours running. Engine alarms for high coolant temperature, low oil pressure, emergency stop activated, battery charging failure, low coolant level, low fuel level, over-speed, under-speed and low battery volts.

Engine alarms included: High coolant temperature, low oil pressure, low coolant level, unexpected shutdown, low fuel level, stop failure, low battery voltage, battery charging alternator failure, over-speed, under-speed, start failure and emergency stop. Support of engines with ECU (J1939, Modbus and other proprietary interfaces); alarm codes displayed in text form.



Alternator alarms included: Overload, unbalanced voltage, over voltage, under voltage, over frequency, under frequency, short circuit and reverse power.

DIMENSIONS, WEIGHTS & SOUND LEVELS

OPEN SET

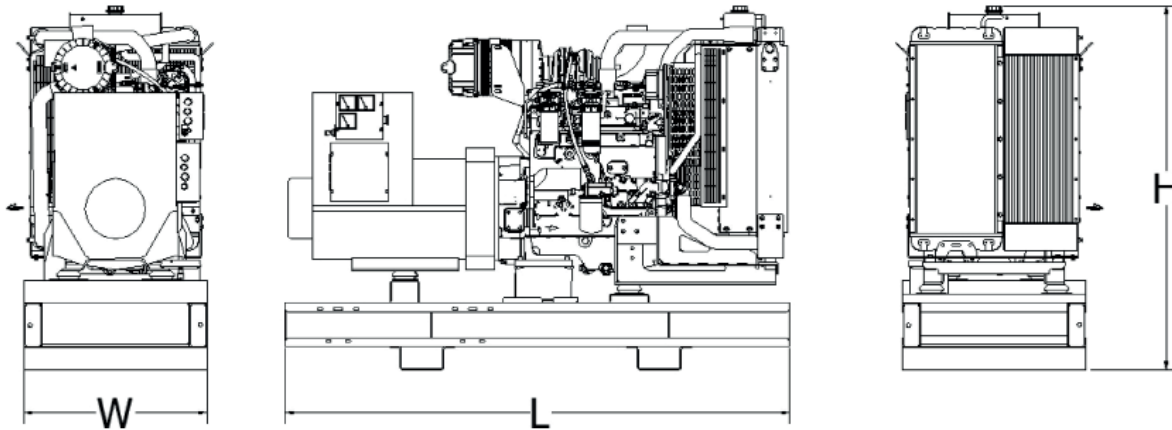

CONFIGURATION	Generator Data *				
	L = Length	W = Width	H = Height	Weight lbs	dBA
Open Set	109"	36.3"	79.7"	TBD	TBD

REV1

HIMOINSA POWER SYSTEMS, INC.

16600 S. Theden Street, Olathe, KS 66062

Tel: 913 495 5557 | Fax: 913 495 5575 www.hipowersystems.com

Codes and Standards Compliances used where applicable

